

# HFR<sup>TM</sup>

313998M

EN

**Hydraulic, Plural-Component, Fixed-Ratio Proportioner.**  
**For pouring and dispensing sealants and adhesives and polyurethane foam.**  
**For professional use only. Not for use in explosive atmospheres.**



### **Important Safety Instructions**

Read all warnings and instructions in this manual. Save these instructions.

See page 4 for model information and maximum working pressure.

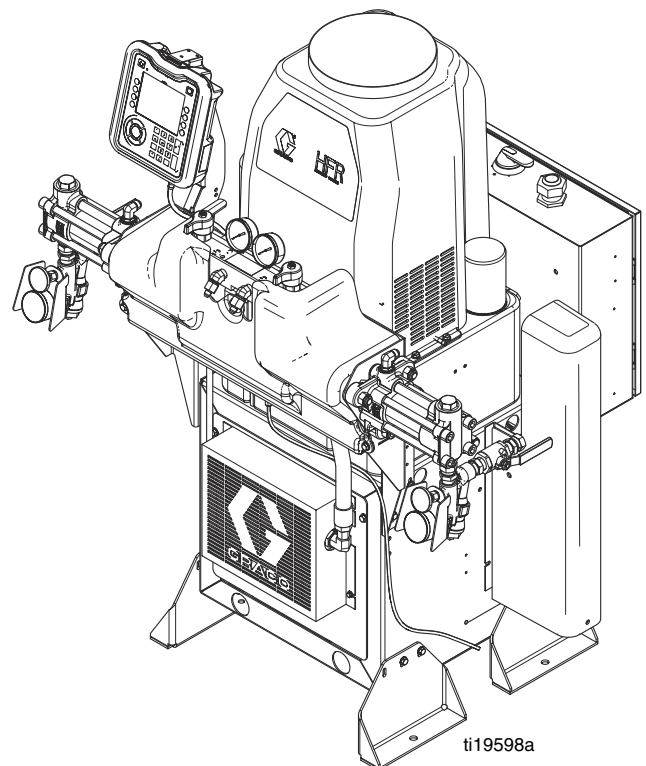

# Contents

<b>Related Manuals</b> .....	<b>3</b>	<b>Logic Drawings</b> .....	<b>74</b>
<b>Models</b> .....	<b>4</b>	230V, 1 Phase, No Heat .....	74
<b>Product Configurator</b> .....	<b>5</b>	230V, 1 Phase, with Heat .....	75
Whip Hose Bundles .....	7	230V, 3 Phase, No Heat .....	77
Individual B (Blue) Heated Whip Hose .....	7	230V, 3 Phase, with Heat .....	78
Individual A (Red) Heated Whip Hose .....	7	400V, 3 Phase, No Heat .....	80
B (Blue) Individual .....	8	400V, 3 Phase, with Heat .....	81
A (Red) Individual .....	9	A (Red) Heat .....	83
Hose Bundling Accessories .....	10	B (Blue) Heat .....	85
Applicator .....	10	DC Hydraulic Power Pack .....	87
B (Blue) Applicator Orifice .....	11	Motor Control Module (MCM) .....	88
Iso A (Red) Applicator Orifice .....	12	Miscellaneous Power .....	90
AC Power Pack with S-Head/L-Head Hoses, Optional Boom .....	13	<b>Technical Data</b> .....	<b>92</b>
Dispense Valve Interface Kit .....	13	<b>Motor Control Module Technical Data</b> .....	<b>93</b>
Flow Meters .....	14	<b>Graco Standard Warranty</b> .....	<b>94</b>
Pump Feed Kits .....	14	<b>Graco Information</b> .....	<b>94</b>
B (Blue) and A (Red) Feed Tanks .....	15		
<b>Warnings</b> .....	<b>17</b>		
<b>Important Two-Component Material Information</b> .....	<b>19</b>		
Isocyanate Conditions .....	19		
Material Self-ignition .....	19		
Keep Components A (Red) and B (Blue) Separate 19			
Moisture Sensitivity of Isocyanates .....	20		
Foam Resins with 245 fa Blowing Agents .....	20		
Changing Materials .....	20		
<b>A (Red) and B (Blue) Components</b> .....	<b>20</b>		
<b>Shutdown</b> .....	<b>21</b>		
<b>Pressure Relief Procedure</b> .....	<b>22</b>		
<b>Flushing</b> .....	<b>23</b>		
<b>Repair</b> .....	<b>24</b>		
Pumpline .....	24		
Hydraulic Power Pack Repair .....	32		
<b>Parts</b> .....	<b>39</b>		
Base Machine .....	39		
Base Machine Sub-Assemblies .....	47		
Power Pack Module Sub-Assemblies .....	54		
Heater Options .....	57		
Heater Sub-Assemblies .....	65		
<b>Kits</b> .....	<b>72</b>		
DC Power Pack Pressure Adjustment Kit, 24C067 72			
DC Power Pack Hydraulic Pressure Adjustment Setup .....	73		

# Related Manuals

Manuals are available at [www.graco.com](http://www.graco.com).

Component manuals in U.S. English:

<b>System Manuals</b>	
313997	HFR Setup-Operation
<b>Power Distribution Box Manual</b>	
3A0239	Power Distribution Boxes Instructions-Parts
<b>Pumpline Manuals</b>	
3A0019	Z-Series Chemical Pumps Instructions-Parts
3A0020	HFR Hydraulic Actuator Instructions-Parts
<b>Feed System Manuals</b>	
3A0238	Dispense Head Hydraulic Power Pack Instructions-Parts
3A0235	Feed Supply Kits Instructions-Parts
3A0395	Stainless Steel Tank Feed Systems Instructions-Parts
3A1299	Carbon Steel Tank Feed Systems Instructions-Parts
309572	Heated Hose, Instructions-Parts
3A0237	Heated Hoses and Applicator Kits, Instructions-Parts
<b>Dispense Valve Manuals</b>	
313872	EP™ Gun
313536	GX-16, Operation
312185	MD2 Valve, Instructions-Parts
312752	S-Head Operation-Parts
312753	L-Head Operation-Parts
309550	Fusion® AP Gun
309856	Fusion MP Gun
312666	Fusion CS Gun
<b>Accessory Manuals</b>	
3A1149	HFR Discrete Gateway Module Kits Manual

# Models

See **Product Configurator** on page 5 for detailed product configuration information.

System	Full Load Peak Amps Per Phase*	Voltage (phase)	System Watts†	Primary Heater Watts (per heater)	Max Flow Rate◆** lb/min (kg/min)	Approximate Output per Cycle (A+B)** gal. (liter)	Hydraulic Pressure Ratio**	Maximum Fluid Working Pressure ‡ psi (MPa, bar)
HFR, Non-Heated	55 A	230V (1)	12,650	--	50 (22.7)	0.084	1.9:1	3000 (20.7, 207)
	29 A	230V (3)	11,340					
	55 A ★	400V (3)	12,650					
HFR, Heated	116 A	230V (1)	26,680	6,000	50 (22.7)	0.084	1.9:1	3000 (20.7, 207)
	73 A	230V (3)	28,600					
	75 A ★	400V (3)	28,600					

\* Full load amps with all devices operating at maximum capabilities. Fuse requirements at various flow rates and mix chamber sizes may be less.

\*\* Values are dependent on installed pump size. Values shown are for largest available pump size.

† 210 ft (64 m) maximum heated hose length, including whip hose.

◆ Flow rate is independent of frequency 50/60 Hz.

★  approved.

‡ The maximum fluid working pressure for the base machine without hoses is 3000 psi (20.7 MPa, 207 bar). If hoses rated at less than 3000 psi are installed, the system maximum fluid working pressure becomes the rating of the hoses. If 2000 psi hoses were purchased and installed by Graco, the working pressure for the machine is already setup for the lower 2000 psi (13.8 MPa, 138 bar) working pressure by Graco. If the machine was purchased without hoses and aftermarket hoses rated at or above 3000 psi are to be installed, see **Adjust Motor Control Module Selector Switch** on page 34 for the procedure to setup the machine for higher rated hoses. The change in working pressure is made by changing a rotary switch setting in the Motor Control Module. The minimum pressure rating for hoses is 2000 psi. Do not install hoses with a pressure rating lower than 2000 psi.



# Product Configurator

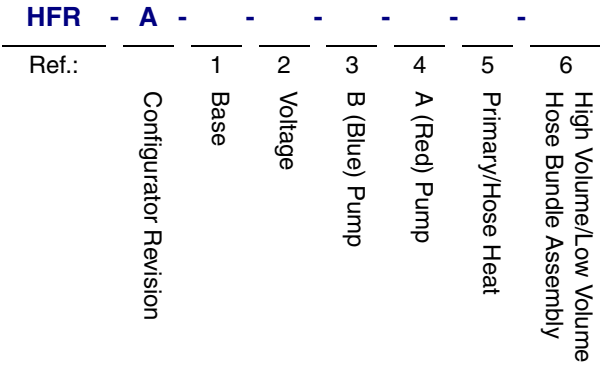

An example of the product configurator would be the following configurator code.

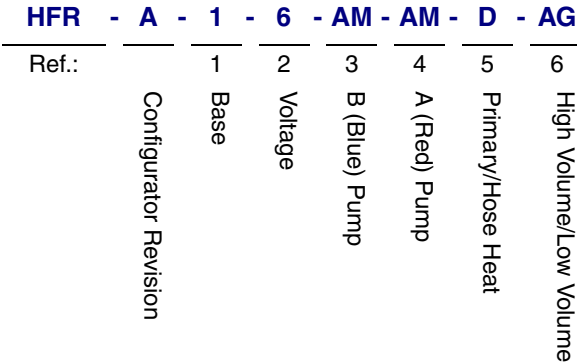

The following part number fields apply for the HFR part numbering configurator fields.

Ref. 1	Part	Base Unit
1		HFR Base Unit, Carbon Steel
2		HFR Base Unit, Stainless Steel
Ref. 2	Part	Voltage
1		230V, 1 phase; No Heat
2		230V, 1 phase; Maximum of Two 6 kW Primary Heater and One Zone of Hose Heat
3		230V, 3 phase; No Heat
4		230V, 3 phase; Maximum of Two 6 kW Primary Heaters and Two Zones of Hose Heat
5		400V, 3 phase; No heat
6		400V, 3 phase; Maximum of Two 6 kW Primary Heaters and Two Zones of Hose Heat

Ref. 3	Part	B (Blue) Pump †
AA	L010S1	10 cc Stainless Steel
AB	L015S1	15 cc Stainless Steel
AC	L020S1	20 cc Stainless Steel
AD	L025S1	25 cc Stainless Steel
AE	L030S1	30 cc Stainless Steel
AF	L040S1	40 cc Stainless Steel
AG	L050S1	50 cc Stainless Steel
AH	L060S1	60 cc Stainless Steel
AJ	L080S1	80 cc Stainless Steel
AK	L100S1	100 cc Stainless Steel
AL	L120S1	120 cc Stainless Steel
AM	L160S1	160 cc Stainless Steel
AN	L005S1	5 cc Stainless Steel
AP	L086S1	86 cc Stainless Steel
AQ	L065S1	65 cc Stainless Steel
Ref. 4	Part	A (Red) Pump †
Code, Part, and Description for Ref. 4 are the same as Ref. 3		

Ref. 5	Part	Primary/Hose Heat
A		No Heat
B		A (Red) and B (Blue) Primary Heaters
C		A (Red) and B (Blue) Primary Heaters, One Zone of Hose Heat
D		A (Red) and B (Blue) Primary Heaters, A (Red) and B (Blue) Hose Heat
E		A (Red) and B (Blue) Hose Heat, Carbon Steel
F		A (Red) and B (Blue) Hose Heat, Stainless Steel
G		B (Blue) Primary Heaters, B (Blue) Hose Heat
Ref. 6	Part	B (Blue) Applicator Hose or High Volume/ Low Volume Hose Bundle Assembly
NN	--	No Hose
AA	24D108	Dual Hose, 2:1, 1/4 x 3/8, 5 ft, Stainless Steel, 3500 psi
AB	24D109	Dual Hose, 2:1, 1/4 x 3/8, 10 ft, Stainless Steel, 3500 psi
AC	24D110	Dual Hose, 2:1, 1/4 x 3/8, 25 ft, Stainless Steel, 3500 psi
AD	24D111	Dual Hose, 2:1, 1/4 x 3/8, 50 ft, Stainless Steel, 3500 psi
AE	24D112	Dual Hose, 1:1, 3/8 x 3/8, 5 ft, Stainless Steel, 3500 psi
AF	24D113	Dual Hose, 1:1, 3/8 x 3/8, 10 ft, Stainless Steel, 3500 psi
AG	24D114	Dual Hose, 1:1, 3/8 x 3/8, 25 ft, Stainless Steel, 3500 psi
AH	24D115	Dual Hose, 1:1, 3/8 x 3/8, 50 ft, Stainless Steel, 3500 psi
BA	24D116	Dual Hose, 2:1, 1/4 x 3/8, 5 ft, Stainless Steel, 3500 psi
BB	24D117	Dual Hose, 2:1, 1/4 x 3/8, 10 ft, Carbon Steel, 3500 psi
BC	24D118	Dual Hose, 2:1, 1/4 x 3/8, 25 ft, Carbon Steel, 3500 psi
BD	24D119	Dual Hose, 2:1, 1/4 x 3/8, 50 ft, Carbon Steel, 3500 psi
BE	24D120	Dual Hose, 1:1, 3/8 x 3/8, 5 ft, Carbon Steel, 3500 psi
BF	24D121	Dual Hose, 1:1, 3/8 x 3/8, 10 ft, Carbon Steel, 3500 psi
BG	24D122	Dual Hose, 1:1, 3/8 x 3/8, 25 ft, Carbon Steel, 3500 psi
BH	24D123	Dual Hose, 1:1, 3/8 x 3/8, 50 ft, Carbon Steel, 3500 psi
CA	24E968	Single Hose, 1:1, 1/4 x 1/4, 10 ft, Carbon Steel, 2000 psi
CB	24E963	Single Hose, 1:1, 1/4 x 1/4, 25 ft, Carbon Steel, 2000 psi
CC	24E964	Single Hose, 1:1, 1/4 x 1/4, 50 ft, Carbon Steel, 2000 psi
CD	24D124	Single Hose, 2:1, 1/4 x 3/8, 25 ft, Carbon Steel, 2000 psi
CE	24D125	Single Hose, 2:1, 1/4 x 3/8, 50 ft, Carbon Steel, 2000 psi

CF	24E969	Single Hose, 1:1, 3/8 x 3/8, 10 ft, Carbon Steel, 2000 psi
CG	24D126	Single Hose, 1:1, 3/8 x 3/8, 25 ft, Carbon Steel, 2000 psi
CH	24D127	Single Hose, 1:1, 3/8 x 3/8, 50 ft, Carbon Steel, 2000 psi
CJ	24E965	Single Hose, 1:1, 1/2 x 1/2, 50 ft, Carbon Steel, 2000 psi
CK	24E966	Single Hose, 1:1, 1/4 x 1/4, 50 ft, Carbon Steel, 3500 psi
CL	24D129	Single Hose, 2:1, 1/4 x 3/8, 50 ft, Carbon Steel, 3500 psi
CM	24D131	Single Hose, 1:1, 3/8 x 3/8, 50 ft, Carbon Steel, 3500 psi
CN	24E967	Single Hose, 1:1, 1/2 x 1/2, 50 ft, Carbon Steel, 3500 psi

† Pump size listed is the combined volume dispensed in one extending stroke and one retracting stroke.

## Whip Hose Bundles

Part	Description
24H076	10 ft (3 m) long, 1/4 in. (6 mm) ID, Carbon Steel, Single Zone
24H077	10 ft (3 m) long, 3/8 in. (10 mm) ID, Carbon Steel, Single Zone
24H078	10 ft (3 m) long, 1/4 in. (6 mm) ID, Carbon Steel, Dual Zone
24H079	10 ft (3 m) long, 3/8 in. (10 mm) ID, Carbon Steel, Dual Zone
24H080	10 ft (3 m) long, 1/4 in. (6 mm) ID, Stainless Steel, Single Zone
24H081	10 ft (3 m) long, 3/8 in. (10 mm) ID, Stainless Steel, Single Zone
24H082	10 ft (3 m) long, 1/4 in. (6 mm) ID, Stainless Steel, Dual Zone
24H083	10 ft (3 m) long, 3/8 in. (10 mm) ID, Stainless Steel, Dual Zone

## Individual B (Blue) Heated Whip Hose

Part	Description
24E950	10 ft (3 m) long, 1/4 in. (6 mm) ID, Carbon Steel, Single Zone, 3500 psi
24E952	10 ft (3 m) long, 3/8 in. (10 mm) ID, Carbon Steel, Single Zone, 3500 psi
24H086	10 ft (3 m) long, 1/4 in. (6 mm) ID, Carbon Steel, Dual Zone, 3500 psi
24H088	10 ft (3 m) long, 3/8 in. (10 mm) ID, Carbon Steel, Dual Zone, 3500 psi
24H090	10 ft (3 m) long, 1/4 in. (6 mm) ID, Stainless Steel, Single Zone, 3500 psi
24H092	10 ft (3 m) long, 3/8 in. (10 mm) ID, Stainless Steel, Single Zone, 3500 psi
24H094	10 ft (3 m) long, 1/4 in. (6 mm) ID, Stainless Steel, Dual Zone, 3500 psi
24H096	10 ft (3 m) long, 3/8 in. (10 mm) ID, Stainless Steel, Dual Zone, 3500 psi

24H225	5 ft (1.5 m) long, 1/4 in. (6 mm) ID, Carbon Steel, Single Zone, 3500 psi
24H227	5 ft (1.5 m) long, 3/8 in. (10 mm) ID, Carbon Steel, Single Zone, 3500 psi
24H229	5 ft (1.5 m) long, 1/4 in. (6 mm) ID, Carbon Steel, Dual Zone, 3500 psi
24H231	5 ft (1.5 m) long, 3/8 in. (10 mm) ID, Carbon Steel, Dual Zone, 3500 psi
24H233	5 ft (1.5 m) long, 1/4 in. (6 mm) ID, Stainless Steel, Single Zone, 3500 psi
24H235	5 ft (1.5 m) long, 3/8 in. (10 mm) ID, Stainless Steel, Single Zone, 3500 psi
24H237	5 ft (1.5 m) long, 1/4 in. (6 mm) ID, Stainless Steel, Dual Zone, 3500 psi
24H239	5 ft (1.5 m) long, 3/8 in. (10 mm) ID, Stainless Steel, Dual Zone, 3500 psi

## Individual A (Red) Heated Whip Hose

Part	Description
24E949	10 ft (3 m) long, 1/4 in. (6 mm) ID, Carbon Steel, Single Zone, 3500 psi
24E951	10 ft (3 m) long, 3/8 in. (10 mm) ID, Carbon Steel, Single Zone, 3500 psi
24H085	10 ft (3 m) long, 1/4 in. (6 mm) ID, Carbon Steel, Dual Zone, 3500 psi
24H087	10 ft (3 m) long, 3/8 in. (10 mm) ID, Carbon Steel, Dual Zone, 3500 psi
24H089	10 ft (3 m) long, 1/4 in. (6 mm) ID, Stainless Steel, Single Zone, 3500 psi
24H091	10 ft (3 m) long, 3/8 in. (10 mm) ID, Stainless Steel, Single Zone, 3500 psi
24H093	10 ft (3 m) long, 1/4 in. (6 mm) ID, Stainless Steel, Dual Zone, 3500 psi
24H095	10 ft (3 m) long, 3/8 in. (10 mm) ID, Stainless Steel, Dual Zone, 3500 psi
24H224	5 ft (1.5 m) long, 1/4 in. (6 mm) ID, Carbon Steel, Single Zone, 3500 psi
24H226	5 ft (1.5 m) long, 3/8 in. (10 mm) ID, Carbon Steel, Single Zone, 3500 psi
24H228	5 ft (1.5 m) long, 1/4 in. (6 mm) ID, Carbon Steel, Dual Zone, 3500 psi
24H230	5 ft (1.5 m) long, 3/8 in. (10 mm) ID, Carbon Steel, Dual Zone, 3500 psi
24H232	5 ft (1.5 m) long, 1/4 in. (6 mm) ID, Stainless Steel, Single Zone, 3500 psi
24H234	5 ft (1.5 m) long, 3/8 in. (10 mm) ID, Stainless Steel, Single Zone, 3500 psi
24H236	5 ft (1.5 m) long, 1/4 in. (6 mm) ID, Stainless Steel, Dual Zone, 3500 psi
24H238	5 ft (1.5 m) long, 3/8 in. (10 mm) ID, Stainless Steel, Dual Zone, 3500 psi

## Hoses

Part	Description
24D111	Dual Hose, 2:1, 1/4 x 3/8, 50 ft, Stainless Steel, 3500 psi
24D115	Dual Hose, 1:1, 3/8 x 3/8, 50 ft, Stainless Steel, 3500 psi
24D119	Dual Hose, 2:1, 1/4 x 3/8, 50 ft, Carbon Steel, 3500 psi
24D123	Dual Hose, 1:1, 3/8 x 3/8, 50 ft, Carbon Steel, 3500 psi
24E964	Single Hose, 1:1, 1/4 x 1/4, 50 ft, Carbon Steel, 2000 psi
24D125	Single Hose, 2:1, 1/4 x 3/8, 50 ft, Carbon Steel, 2000 psi
24D127	Single Hose, 1:1, 3/8 x 3/8, 50 ft, Carbon Steel, 2000 psi
24E965	Single Hose, 1:1, 1/2 x 1/2, 50 ft, Carbon Steel, 2000 psi
24E966	Single Hose, 1:1, 1/4 x 1/4, 50 ft, Carbon Steel, 3500 psi
24D129	Single Hose, 2:1, 1/4 x 3/8, 50 ft, Carbon Steel, 3500 psi
24D131	Single Hose, 1:1, 3/8 x 3/8, 50 ft, Carbon Steel, 3500 psi
24E967	Single Hose, 1:1, 1/2 x 1/2, 50 ft, Carbon Steel, 3500 psi

## B (Blue) Individual

Part	Description
24E902	Heated Hose, 5 ft, 1/4, Carbon Steel, 3500 psi
24E904	Heated Hose, 10 ft, 1/4, Carbon Steel, 3500 psi
24E906	Heated Hose, 25 ft, 1/4, Carbon Steel, 3500 psi
24E908	Heated Hose, 50 ft, 1/4, Carbon Steel, 3500 psi
24E910	Heated Hose, 5 ft, 3/8, Carbon Steel, 3500 psi
24E912	Heated Hose, 10 ft, 3/8, Carbon Steel, 3500 psi
24E914	Heated Hose, 25 ft, 3/8, Carbon Steel, 3500 psi
24E916	Heated Hose, 50 ft, 3/8, Carbon Steel, 3500 psi
24E918	Heated Hose, 5 ft, 1/2, Carbon Steel, 3500 psi
24E920	Heated Hose, 10 ft, 1/2, Carbon Steel, 3500 psi
24E922	Heated Hose, 25 ft, 1/2, Carbon Steel, 3500 psi
24E924	Heated Hose, 50 ft, 1/2, Carbon Steel, 3500 psi
24E926	Heated Hose, 5 ft, 1/4, Stainless Steel, 3500 psi
24E928	Heated Hose, 10 ft, 1/4, Stainless Steel, 3500 psi
24E930	Heated Hose, 25 ft, 1/4, Stainless Steel, 3500 psi
24E932	Heated Hose, 50 ft, 1/4, Stainless Steel, 3500 psi
24E934	Heated Hose, 5 ft, 3/8, Stainless Steel, 3500 psi
24E936	Heated Hose, 10 ft, 3/8, Stainless Steel, 3500 psi
24E938	Heated Hose, 25 ft, 3/8, Stainless Steel, 3500 psi

24E940	Heated Hose, 50 ft, 3/8, Stainless Steel, 3500 psi
24E942	Heated Hose, 5 ft, 1/2, Stainless Steel, 3500 psi
24E944	Heated Hose, 10 ft, 1/2, Stainless Steel, 3500 psi
24E946	Heated Hose, 25 ft, 1/2, Stainless Steel, 3500 psi
24E948	Heated Hose, 50 ft, 1/2, Stainless Steel, 3500 psi
262174	Unheated Hose, 5 ft, 1/4, Carbon Steel, 3500 psi
262176	Unheated Hose, 10 ft, 1/4, Carbon Steel, 3500 psi
262178	Unheated Hose, 25 ft, 1/4, Carbon Steel, 3500 psi
262180	Unheated Hose, 50 ft, 1/4, Carbon Steel, 3500 psi
262182	Unheated Hose, 5 ft, 3/8, Carbon Steel, 3500 psi
262184	Unheated Hose, 10 ft, 3/8, Carbon Steel, 3500 psi
262186	Unheated Hose, 25 ft, 3/8, Carbon Steel, 3500 psi
262188	Unheated Hose, 50 ft, 3/8, Carbon Steel, 3500 psi
262190	Unheated Hose, 5 ft, 1/2, Carbon Steel, 3500 psi
262192	Unheated Hose, 10 ft, 1/2, Carbon Steel, 3500 psi
262194	Unheated Hose, 25 ft, 1/2, Carbon Steel, 3500 psi
262196	Unheated Hose, 50 ft, 1/2, Carbon Steel, 3500 psi
262237	Unheated Hose, 5 ft, 1/4, Stainless Steel, 3500 psi
262239	Unheated Hose, 10 ft, 1/4, Stainless Steel, 3500 psi
262241	Unheated Hose, 25 ft, 1/4, Stainless Steel, 3500 psi
262243	Unheated Hose, 50 ft, 1/4, Stainless Steel, 3500 psi
262245	Unheated Hose, 5 ft, 3/8, Stainless Steel, 3500 psi
262247	Unheated Hose, 10 ft, 3/8, Stainless Steel, 3500 psi
262249	Unheated Hose, 25 ft, 3/8, Stainless Steel, 3500 psi
262251	Unheated Hose, 50 ft, 3/8, Stainless Steel, 3500 psi
262253	Unheated Hose, 5 ft, 3/8, Stainless Steel, 3500 psi
262255	Unheated Hose, 10 ft, 3/8, Stainless Steel, 3500 psi
262257	Unheated Hose, 25 ft, 3/8, Stainless Steel, 3500 psi
262259	Unheated Hose, 50 ft, 3/8, Stainless Steel, 3500 psi

## A (Red) Individual

Part	Description
24E901	Heated Hose, 5 ft, 1/4, Carbon Steel, 3500 psi
24E903	Heated Hose, 10 ft, 1/4, Carbon Steel, 3500 psi
24E905	Heated Hose, 25 ft, 1/4, Carbon Steel, 3500 psi
24E907	Heated Hose, 50 ft, 1/4, Carbon Steel, 3500 psi
24E909	Heated Hose, 5 ft, 3/8, Carbon Steel, 3500 psi
24E911	Heated Hose, 10 ft, 3/8, Carbon Steel, 3500 psi
24E913	Heated Hose, 25 ft, 3/8, Carbon Steel, 3500 psi
24E915	Heated Hose, 50 ft, 3/8, Carbon Steel, 3500 psi
24E917	Heated Hose, 5 ft, 1/2, Carbon Steel, 3500 psi
24E919	Heated Hose, 10 ft, 1/2, Carbon Steel, 3500 psi
24E921	Heated Hose, 25 ft, 1/2, Carbon Steel, 3500 psi
24E923	Heated Hose, 50 ft, 1/2, Carbon Steel, 3500 psi
24E925	Heated Hose, 5 ft, 1/4, Stainless Steel, 3500 psi
24E927	Heated Hose, 10 ft, 1/4, Stainless Steel, 3500 psi
24E929	Heated Hose, 25 ft, 1/4, Stainless Steel, 3500 psi
24E931	Heated Hose, 50 ft, 1/4, Stainless Steel, 3500 psi
24E933	Heated Hose, 5 ft, 3/8, Stainless Steel, 3500 psi
24E935	Heated Hose, 10 ft, 3/8, Stainless Steel, 3500 psi
24E937	Heated Hose, 25 ft, 3/8, Stainless Steel, 3500 psi
24E939	Heated Hose, 50 ft, 3/8, Stainless Steel, 3500 psi
24E941	Heated Hose, 5 ft, 1/2, Stainless Steel, 3500 psi
24E943	Heated Hose, 10 ft, 1/2, Stainless Steel, 3500 psi
24E945	Heated Hose, 25 ft, 1/2, Stainless Steel, 3500 psi
24E947	Heated Hose, 50 ft, 1/2, Stainless Steel, 3500 psi
262173	Unheated Hose, 5 ft, 1/4, Carbon Steel, 3500 psi
262175	Unheated Hose, 10 ft, 1/4, Carbon Steel, 3500 psi
262177	Unheated Hose, 25 ft, 1/4, Carbon Steel, 3500 psi
262179	Unheated Hose, 50 ft, 1/4, Carbon Steel, 3500 psi
262181	Unheated Hose, 5 ft, 3/8, Carbon Steel, 3500 psi
262183	Unheated Hose, 10 ft, 3/8, Carbon Steel, 3500 psi
262185	Unheated Hose, 25 ft, 3/8, Carbon Steel, 3500 psi
262187	Unheated Hose, 50 ft, 3/8, Carbon Steel, 3500 psi
262189	Unheated Hose, 5 ft, 1/2, Carbon Steel, 3500 psi
262191	Unheated Hose, 10 ft, 1/2, Carbon Steel, 3500 psi
262193	Unheated Hose, 25 ft, 1/2, Carbon Steel, 3500 psi
262195	Unheated Hose, 50 ft, 1/2, Carbon Steel, 3500 psi
262236	Unheated Hose, 5 ft, 1/4, Stainless Steel, 3500 psi

262238	Unheated Hose, 10 ft, 1/4, Stainless Steel, 3500 psi
262240	Unheated Hose, 25 ft, 1/4, Stainless Steel, 3500 psi
262242	Unheated Hose, 50 ft, 1/4, Stainless Steel, 3500 psi
262244	Unheated Hose, 5 ft, 3/8, Stainless Steel, 3500 psi
262246	Unheated Hose, 10 ft, 3/8, Stainless Steel, 3500 psi
262248	Unheated Hose, 25 ft, 3/8, Stainless Steel, 3500 psi
262250	Unheated Hose, 50 ft, 3/8, Stainless Steel, 3500 psi
262252	Unheated Hose, 5 ft, 1/2, Stainless Steel, 3500 psi
262254	Unheated Hose, 10 ft, 1/2, Stainless Steel, 3500 psi
262256	Unheated Hose, 25 ft, 1/2, Stainless Steel, 3500 psi
262258	Unheated Hose, 50 ft, 1/2, Stainless Steel, 3500 psi

## Hose Bundling Accessories

Part	Description
24E953	Air Hose, 5 ft
15B280	Air Hose, 10 ft
15C624	Air Hose, 25 ft
15B295	Air Hose, 50 ft
24E900	Signal Cable, 5 pin, Male/Female, 2.0 meter
24E899	Signal Cable, 5 pin, Male/Female, 4.0 meter
24E898	Signal Cable, 5 pin, Male/Female, 8.5 meter
24E897	Signal Cable, 5 pin, Male/Female, 16.0 meter
24E896	Fluid Temperature Sensor Cable, 4 pin, Male/Female, 2.0 meter
24E895	Fluid Temperature Sensor Cable, 4 pin, Male/Female, 3.0 meter
24E894	Fluid Temperature Sensor Cable, 4 pin, Male/Female, 8.0 meter
24E893	Fluid Temperature Sensor Cable, 4 pin, Male/Female, 15.7 meter
24E954	Scuff Guard, 1.75 in. (44 mm), 200 ft (61 m) Roll
24E961	Scuff Guard, 1.75 in. (44 mm), 200 ft (61 m) Roll
261821	Wire Connector, 6AWG (4.11 mm)
24E955	Hose Lacing, 1500 ft (457.2 m) Roll
15B679	Hose Safety Label

## Applicator

Part	Description
24A084	L-Head 6/10 With Calibration Orifice
24A085	L-Head 10/14 With Calibration Orifice
24A086	L-Head 13/20 With Calibration Orifice
24A090	S-Head 6-625 With Calibration Orifice
24A092	S-Head 6-500 L/S With Calibration Orifice
24A093	S-Head 6-625 L/S With Calibration Orifice
24J187	GX-16, 24:1, Straight, Machine Mount
24K233	GX-16, 24:1, Left, Machine Mount
24K234	GX-16, No Orifice, Left, Machine Mount
24E876	GX-16, No Orifice, Straight, Machine Mount
24E877	GX-16, 24:1, Right, Machine Mount
24E878	GX-16, No Orifice, Right, Machine Mount
CS00RD	Fusion CS, 1:1 Only, 0.029
CS01RD	Fusion CS, 1:1 Only, 0.042
CS02RD	Fusion CS, 1:1 Only, 0.052
246100	Fusion AP, 1:1 Only, 0.029
247007	Fusion MP, 1:1 Only, 0.029
246101	Fusion AP, 1:1 Only, 0.042
247019	Fusion MP, 1:1 Only, 0.047
246102	Fusion AP, 1:1 Only, 0.052

247025	Fusion MP, 1:1 Only, 0.057
24D500	Applicator, MD2, 1:1, Soft, Carbon Steel
24D501	Applicator, MD2, 1:1, Soft, Carbon Steel, Electric
24D502	Applicator, MD2, 1:1, Soft, Carbon Steel, Lever
24D503	Applicator, MD2, 1:1, Soft, Stainless Steel
24D504	Applicator, MD2, 1:1, Soft, Stainless Steel, Electric
24D505	Applicator, MD2, 1:1, Soft, Stainless Steel, Lever
24D509	Applicator, MD2, 1:1, Hard, Carbon Steel
24D510	Applicator, MD2, 1:1, Hard, Carbon Steel, Electric
24D511	Applicator, MD2, 1:1, Hard, Carbon Steel, Lever
24D512	Applicator, MD2, 1:1, Hard, Carbon Steel, Pneumatic
24D513	Applicator, MD2, 1:1, Hard, Stainless Steel
24D514	Applicator, MD2, 1:1, Hard, Stainless Steel, Electric
24D515	Applicator, MD2, 1:1, Hard, Stainless Steel, Lever
24D516	Applicator, MD2, 1:1, Hard, Stainless Steel, Pneumatic
24D521	Applicator, MD2, 10:1, Soft, Carbon Steel
24D522	Applicator, MD2, 10:1, Soft, Carbon Steel, Electric
24D523	Applicator, MD2, 10:1, Soft, Carbon Steel, Lever
24D524	Applicator, MD2, 10:1, Soft, Stainless Steel
24D525	Applicator, MD2, 10:1, Soft, Stainless Steel, Electric
24D526	Applicator, MD2, 10:1, Soft, Stainless Steel, Lever
24D530	Applicator, MD2, 10:1, Hard, Carbon Steel
24D531	Applicator, MD2, 10:1, Hard, Carbon Steel, Electric
24D532	Applicator, MD2, 10:1, Hard, Carbon Steel, Lever
24D533	Applicator, MD2, 10:1, Hard, Carbon Steel, Pneumatic
24D534	Applicator, MD2, 10:1, Hard, Stainless Steel
24D535	Applicator, MD2, 10:1, Hard, Stainless Steel, Electric
24D536	Applicator, MD2, 10:1, Hard, Stainless Steel, Lever
24D537	Applicator, MD2, 10:1, Hard, Stainless Steel, Pneumatic
24E505	MD2 Orifice Adapter Kit
257999	EP Pour Gun, Pistol Grip, 1/4 in. Purge Rod
24C932	EP Pour Gun, Machine mount, 1/4 in. Purge Rod
24C933	EP Pour Gun, Pistol Grip, 3/8 in. Purge Rod
24C934	EP Pour Gun, Machine Mount, 3/8 in. Purge Rod
LC0058	Mixer Kit, (10) 3/8 in. x 24 Element with Shroud
LC0059	Mixer Kit, (10) 3/8 in. x 36 Element with Shroud
LC0060	Mixer Kit, (10) 3/8 in. Combo with Shroud
LC0295	Mixer Kit, (10) 1/2 in. x 24 Element with Shroud
LC0296	Mixer Kit, (10) 1/2 in. x 36 Element with Shroud

LC0079	Mixer Pack, (50) 3/8 in. x 24 Element
LC0080	Mixer Pack, (50) 3/8 in. x 24 Element
LC0081	Mixer Pack, (50) 3/8 in. Combo Element
LC0086	Mixer Pack, (250) 3/8 in. x 24 Element
LC0087	Mixer Pack, (250) 3/8 in. x 36 Element
LC0088	Mixer Pack, (250) 3/8 in. Combo Element

## B (Blue) Applicator Orifice

### S-Head and L-Head

Description	Part	For Use With Applicator:
Calibrate	24A036	S-Head Only
0.25	24A037	S-Head Only
0.35	24A038	S-Head Only
0.50	24A039	S-Head Only
0.60	24A040	S-Head Only
0.70	24A041	S-Head Only
0.80	24A042	S-Head Only
0.90	24A043	S-Head Only
1.00	24A044	S-Head Only
1.10	24A045	S-Head Only
1.20	24A046	S-Head Only
1.30	24A047	S-Head Only
1.40	24A050	S-Head Only
1.50	24A051	S-Head Only
1.60	24A052	S-Head Only
1.70	24A053	S-Head Only
1.80	24A054	S-Head Only
1.90	24A055	S-Head Only
2.00	24A056	S-Head Only
2.50	24A057	S-Head Only
3.00	24A058	S-Head Only
3.50	24A059	S-Head Only
4.00	24A060	S-Head Only
4.20	24A061	S-Head Only
4.50	24A062	S-Head Only
5.00	24A063	S-Head Only
5.50	24A064	S-Head Only
6.00	24A065	S-Head Only
6.50	24A066	S-Head Only
7.00	24A067	S-Head Only
Calibrate	M0934A-4	L-Head Only
0.25	247761	L-Head Only
0.45	247762	L-Head Only
0.5	247763	L-Head Only
0.75	247764	L-Head Only
0.8	247765	L-Head Only
0.85	247766	L-Head Only
1	247767	L-Head Only
1.1	247811	L-Head Only
1.2	247848	L-Head Only
1.25	248858	L-Head Only

1.3	247859	L-Head Only
1.4	247860	L-Head Only
1.5	247861	L-Head Only
1.6	247862	L-Head Only
1.65	247863	L-Head Only
1.7	247864	L-Head Only
1.75	247865	L-Head Only
1.8	247866	L-Head Only
1.9	247867	L-Head Only
2	247868	L-Head Only
2.4	247869	L-Head Only
3.2	247870	L-Head Only
3.6	247871	L-Head Only
4.2	247872	L-Head Only
5	247873	L-Head Only
5.6	247874	L-Head Only

### GX-16

Description	Part
257701	0.011 in. Orifice
257702	0.013 in. Orifice
257703	0.016 in. Orifice
257704	0.018 in. Orifice
257705	0.020 in. Orifice
257706	0.022 in. Orifice
257707	0.023 in. Orifice
257708	0.024 in. Orifice
257709	0.025 in. Orifice
257710	0.026 in. Orifice
257711	0.028 in. Orifice
257712	0.029 in. Orifice
257713	0.032 in. Orifice
257714	0.035 in. Orifice
257715	0.036 in. Orifice
257716	0.038 in. Orifice
257717	0.039 in. Orifice
257718	0.040 in. Orifice
257719	0.042 in. Orifice
257720	0.043 in. Orifice
257721	0.044 in. Orifice
257722	0.049 in. Orifice
257723	0.052 in. Orifice
257724	0.061 in. Orifice
24K682	0.085 in. Orifice

### EP™ Gun

Description	Part	For Use With Applicator:
Orifice Kit	24E250	EP 250, 6 Blue, 6 Red
0.51 mm Poly Orifice	24C751	EP 250 Poly Side Orifice, Std
0.79 mm Poly Orifice	24C752	EP 250 Poly Side Orifice, Std
1.19 mm Poly Orifice	24C753	EP 250 Poly Side Orifice, Std

1.52 mm Poly Orifice	24C754	EP 250 Poly Side Orifice, Std Orifice
1.70mm Poly Orifice	24C755	EP 250 Poly Side Orifice, Std Orifice
2.18 mm Poly Orifice	24C756	EP 250 Poly Side Orifice, Std Orifice
0.41 mm Poly Orifice	24C805	EP 250 Poly Side Orifice
0.61 mm Poly Orifice	24C806	EP 250 Poly Side Orifice
0.71 mm Poly Orifice	24C807	EP 250 Poly Side Orifice
0.89 mm Poly Orifice	24C808	EP 250 Poly Side Orifice
0.99 mm Poly Orifice	24C809	EP 250 Poly Side Orifice
1.07 mm Poly Orifice	24C810	EP 250 Poly Side Orifice
1.32 mm Poly Orifice	24C811	EP 250 Poly Side Orifice
1.40 mm Poly Orifice	24C812	EP 250 Poly Side Orifice
1.60 mm Poly Orifice	24C813	EP 250 Poly Side Orifice
1.85 mm Poly Orifice	24C815	EP 250 Poly Side Orifice
Orifice Kit	24E251	EP 375, 6 Blue, 6 Red
0.51 mm Poly Orifice	24C761	EP 375 Poly Side Orifice, Std Orifice
0.79 mm Poly Orifice	24C762	EP 375 Poly Side Orifice, Std Orifice
1.19 mm Poly Orifice	24C763	EP 375 Poly Side Orifice, Std Orifice
1.52 mm Poly Orifice	24C764	EP 375 Poly Side Orifice, Std Orifice
1.70 mm Poly Orifice	24C765	EP 375 Poly Side Orifice, Std Orifice
2.18 mm Poly Orifice	24C766	EP 375 Poly Side Orifice, Std Orifice
0.41 mm Poly Orifice	24C794	EP 375 Poly Side Orifice
0.61 mm Poly Orifice	24C795	EP 375 Poly Side Orifice
0.71 mm Poly Orifice	24C796	EP 375 Poly Side Orifice
0.89 mm Poly Orifice	24C797	EP 375 Poly Side Orifice
0.99 mm Poly Orifice	24C798	EP 375 Poly Side Orifice
1.07 mm Poly Orifice	24C799	EP 375 Poly Side Orifice
1.32 mm Poly Orifice	24C800	EP 375 Poly Side Orifice
1.40 mm Poly Orifice	24C801	EP 375 Poly Side Orifice
1.60 mm Poly Orifice	24C802	EP 375 Poly Side Orifice
1.85 mm Poly Orifice	24C804	EP 375 Poly Side Orifice

## Iso A (Red) Applicator Orifice

### S-Head and L-Head

The A (Red) applicator orifices for the S-Head and L-Head are the same as the B (Blue) applicator orifices. See page 11.

### GX-16

Description	Part
257701	0.011 in. Orifice
257702	0.013 in. Orifice
257703	0.016 in. Orifice
257704	0.018 in. Orifice
257705	0.020 in. Orifice
257706	0.022 in. Orifice
257707	0.023 in. Orifice
257708	0.024 in. Orifice
257709	0.025 in. Orifice
257710	0.026 in. Orifice
257711	0.028 in. Orifice
257712	0.029 in. Orifice
257713	0.032 in. Orifice
257714	0.035 in. Orifice
257715	0.036 in. Orifice
257716	0.038 in. Orifice
257717	0.039 in. Orifice
257718	0.040 in. Orifice
257719	0.042 in. Orifice
257720	0.043 in. Orifice
257721	0.044 in. Orifice
257722	0.049 in. Orifice
257723	0.052 in. Orifice
257724	0.061 in. Orifice
24K682	0.085 in. Orifice

### EP Gun

Description	Part	For Use With Applicator:
0.51 mm Iso Orifice	24D223	EP 250 Iso Side Orifice, Std
0.79 mm Iso Orifice	24D224	EP 250 Iso Side Orifice, Std
1.19 mm Iso Orifice	24D225	EP 250 Iso Side Orifice, Std
1.52 mm Iso Orifice	24D226	EP 250 Iso Side Orifice, Std
1.70mm Iso Orifice	24D227	EP 250 Iso Side Orifice, Std
2.18 mm Iso Orifice	24D228	EP 250 Iso Side Orifice, Std
0.41 mm Iso Orifice	24D229	EP 250 Iso Side Orifice
0.61 mm Iso Orifice	24D230	EP 250 Iso Side Orifice



0.71 mm Iso Orifice	24D231	EP 250 Iso Side Orifice
0.89 mm Iso Orifice	24D232	EP 250 Iso Side Orifice
0.99 mm Iso Orifice	24D233	EP 250 Iso Side Orifice
1.07 mm Iso Orifice	24D234	EP 250 Iso Side Orifice
1.32 mm Iso Orifice	24D235	EP 250 Iso Side Orifice
1.40 mm Iso Orifice	24D236	EP 250 Iso Side Orifice
1.60 mm Iso Orifice	24D237	EP 250 Iso Side Orifice
1.85 mm Iso Orifice	24D238	EP 250 Iso Side Orifice
0.51 mm Iso Orifice	24D239	EP 375 Iso Side Orifice, Std
0.79 mm Iso Orifice	24D240	EP 375 Iso Side Orifice, Std
1.19 mm Iso Orifice	24D241	EP 375 Iso Side Orifice, Std
1.52 mm Iso Orifice	24D242	EP 375 Iso Side Orifice, Std
1.70 mm Iso Orifice	24D243	EP 375 Iso Side Orifice, Std
2.18 mm Iso Orifice	24D244	EP 375 Iso Side Orifice, Std
0.41 mm Iso Orifice	24D245	EP 375 Iso Side Orifice
0.61 mm Iso Orifice	24D246	EP 375 Iso Side Orifice
0.71 mm Iso Orifice	24D247	EP 375 Iso Side Orifice
0.89 mm Iso Orifice	24D248	EP 375 Iso Side Orifice
0.99 mm Iso Orifice	24D249	EP 375 Iso Side Orifice
1.07 mm Iso Orifice	24D250	EP 375 Iso Side Orifice
1.32 mm Iso Orifice	24D251	EP 375 Iso Side Orifice
1.40 mm Iso Orifice	24D252	EP 375 Iso Side Orifice
1.60 mm Iso Orifice	24D253	EP 375 Iso Side Orifice
1.85 mm Iso Orifice	24D254	EP 375 Iso Side Orifice

## AC Power Pack with S-Head/L-Head Hoses, Optional Boom

Part	Description
24D829	230V, Boom, L-Head Hoses
24D830	230V, Boom, S-Head Hoses
24D834	400V, Boom, L-Head Hoses
24D835	400V, Boom, S-Head Hoses
24D831	230V, L-Head Hoses, No Boom
24D832	230V, S-Head Hoses, No Boom
24D836	400V, L-Head Hoses, No Boom
24D837	400V, S-Head Hoses, No Boom
24F297	230V, L-Head Application, No Boom, No Hoses
24J912	230V, S-Head Application, No Boom, No Hoses
24F298	400V, L-Head Application, No Boom, No Hoses
24J913	230V, S-Head Application, No Boom, No Hoses
257798	Power Pack GX-16 Connection Kit
24E347	Hydraulic Power Pack Level Sensor Kit
24C872	Hydraulic Power Pack Pressure Gauge Kit
24E348	Hydraulic Power Pack Temperature Sensor
124217	Power Pack Accumulator Charging kit

## Dispense Valve Interface Kit

Part	Description
24C757	MD2 Valve Solenoid, Machine Mount
24D160	MD2 Valve Solenoid, Remote Mount
24D161	Auto-Fusion Solenoid for Fusion Dispense Valve
24C067	Fusion Gun Pressure Adjust Kit

## Flow Meters

### Flow Meter Electronics (Necessary)

Part	Description
24J318	Flow Meter Electronics Kit

### “A” and “B” Side Flow Meter (One for each side)

Part	Description
24J319	S3000 Flow Meter Kit (0.01 to 0.53 gpm, 50 to 2000 cc per min) (1 to 1000 cps)
24J320	G3000 Flow Meter Kit (0.02 to 1.0 gpm, 75 to 3800 cc per min) (20 to 3000 cps)
24J321	G3000HR Flow Meter Kit (0.01 to 0.5 gpm, 38 to 1900 cc per min) (20 to 3000 cps)
24J322	HG6000 Flow Meter Kit (0.013 to 6.0 gpm, 50 to 22,700 cc per min) (30 to 1,000,000 cps)
24J323	HG6000HR Flow Meter Kit (0.007 to 2.0 gpm, 25 to 7571 cc per min) (30 to 1,000,000,cps)

### Flow Meter Calibration Kit (per applicator)

Part	Description
24J324	L-Head Flow Meter Calibration Kit
24J325	S-Head Flow Meter Calibration Kit
24J326	P2 Flow Meter Calibration Kit
24J357	GX-16 Flow Meter Calibration Kit
24F227	EP/Fusion Flow Meter Calibration Kit
255247	MD2 1:1 Flow Meter Calibration Kit
255245	MD2 10:1 Flow Meter Calibration Kit

## Pump Feed Kits

Part	Description
246081	2:1 (Air/Fluid) Carbon Steel Complete Supply Pump Kit
246369	H515 (Air/Fluid) Carbon Steel Complete Supply Pump Kit
246375	H716 (Air/Fluid) Carbon Steel Complete Supply Pump Kit
24D328	H1050 (Air/Fluid) Carbon Steel Complete Supply Pump Kit
257769	High-Flo® (Air/Fluid) Carbon Steel Complete Supply Pump Kit
24D091	2:1 (Air/Fluid) Stainless Steel Complete Supply Pump Kit

24D092	H515 (Air/Fluid) Stainless Steel Complete Supply Pump Kit
24D093	H716 (Air/Fluid) Stainless Steel Complete Supply Pump Kit
24D094	H1050 (Air/Fluid) Stainless Steel Complete Supply Pump Kit
24D095	5:1 Monarch 55G Stainless Steel Complete Supply Pump Kit
24D096	5:1 Monarch 5G Stainless Steel Complete Supply Pump Kit
257777	High-Flo Stainless Steel Complete Supply Pump Kit
246366	Husky™ 515 Pump, Drum with Riser Tube
246367	Husky 716 Pump, Drum with Riser Tube
24D329	Husky 1050 Pump, Drum with Riser Tube
233052	Husky 515 Diaphragm Pump, Drum with Riser Tube
233057	Husky 716 Diaphragm Pump, Drum with Riser Tube
24D097	Husky 1050 SS Pump, Drum with Riser Tube
295616	2:1 (Air/Fluid) Stainless Steel Supply Pumps with Riser Tubes
24D098	5:1 Monarch, 5G, Stainless Steel Supply Pumps with Riser Tubes
24D099	5:1 Monarch, 55G, Stainless Steel Supply Pumps with Riser Tubes
246481	Husky 515 Pump with Carbon Steel Fluid Plumbing
246482	Husky 716 Pump with Carbon Steel Fluid Plumbing
24D332	Husky 1050 Pump with Carbon Steel Fluid Plumbing
246898	2:1 Supply Pump with Carbon Steel Fluid Plumbing
24D100	Husky 515 Pump with Stainless Steel Fluid Plumbing
24D101	Husky 716 Pump with Stainless Steel Fluid Plumbing
24D102	Husky 1050 Pump with Stainless Steel Fluid Plumbing
24D103	2:1 Supply Pump with Stainless Steel Fluid Plumbing
24D104	5:1 Monarch Pump with Stainless Steel Fluid Plumbing
24D105	5:1 Monarch Pump with Stainless Steel Fluid Plumbing
24E396	One 2:1 T-2 Pump, Carbon Steel
24E397	One 2:1 T-2 Pump, Stainless Steel
24E398	One Monarch 5:1 Pump, 5G
24E399	One Monarch 5:1 Pump, 55G
246419	Carbon Steel Riser Tube Assembly
246477	Carbon Steel Return Tube
246483	Air Supply for Feed Pump and Gun

247616	Desiccant Dryer
15C381	Desiccant Dryer Cartridge
233048	Drum Pump Accessory Kit
24D106	Stainless Steel Return Tube Accessory Kit
24D107	Stainless Steel Circulation Accessory
24E379	Carbon Steel Circulation Accessory Kit
244053	26 sq. in., 60 mesh, Stainless Steel Fluid Filter
116178	26 sq. in., 30 mesh, Stainless Steel Fluid Filter Element
116179	26 sq. in., 60 mesh, Stainless Steel Fluid Filter Element
116180	26 sq. in., 100 mesh, Stainless Steel Fluid Filter Element
116181	26 sq. in., 200 mesh, Stainless Steel Fluid Filter Element
213058	36 sq. in., 60 mesh, Carbon Steel Fluid Filter
108106	36 sq. in., 30 mesh, Carbon Steel Fluid Filter Element
108107	36 sq. in., 60 mesh, Carbon Steel Fluid Filter Element
108108	36 sq. in., 100 mesh, Carbon Steel Fluid Filter Element
108109	36 sq. in., 150 mesh, Carbon Steel Fluid Filter Element
108110	36 sq. in., 200 mesh, Carbon Steel Fluid Filter Element

## B (Blue) and A (Red) Feed Tanks

Part	Description
24D562	38L Tank, No Agitation, Chiller, Desiccant, 2 Level Sensors
24D564	38L Tank, Agitation, Chiller, Desiccant, 2 Level Sensors
24D565	75L Tank, No Agitation, Chiller, Desiccant, 2 Level Sensors
24C317	75L Tank, Agitation, Chiller, Desiccant, 2 Level Sensors
24D568	38L Tank, No Agitation, No Level Sensors
24D569	38L Tank, No Agitation, 2 Level Sensors
24D570	38L Tank, Agitation, 2 Level Sensors
24D571	38L Tank, Agitation, Slinger Plate, 2 Level Sensors
24D572	38L Tank, Agitation, Slinger Plate, Heat, Insulation, 2 Level Sensors
24D573	38L Tank, Agitation, Heat, Insulation, 2 Level Sensors
24D574	75L Tank, No Agitation, No Level Sensors
24D575	75L Tank, No Agitation, 2 Level Sensors
24D576	75L Tank, Agitation, 2 Level Sensors
24D577	75L Tank, Agitation, Slinger Plate, 2 Level Sensors

24D578	75L Tank, Agitation, Slinger Plate, Heat, Insulation, 2 Level Sensors
24D579	75L Tank, Agitation, Heat, Insulation, 2 Level Sensors
257757	Insulator Blanket for 38L Tank
257758	Insulator Blanket for 75L Tank
257770	Refill Kit For Customer Supplied Feed System
257778	Nitrogen Kit For 1 Tank
257779	Nitrogen Kit For 2 Tanks
257916	Vacuum Pump Kit, 6.9 cfm, 1st, 230V, 1 phase
24D271	3rd Level Sensor Prox Switch Option
LC0097	Desiccant Dryer, 3/8 in. Npt With Adapter And Cartridge
LC0098	Desiccant Dryer Refill Cartridge
24G952	20gal (75L) Carbon Steel Tank, 2 Level Sensors
24G953	20gal (75L) Carbon Steel Tank, 2 Level Sensors, Variable Speed Pneumatic Agitator
24G955	20gal (75L) Carbon Steel Tank, 2 Level Sensors, Variable Speed Electric Agitator
24G956	20gal (75L) Carbon Steel Tank, 2 Level Sensors, Chiller Control Valve, Heat Exchanger
24G957	20gal (75L) Carbon Steel Tank, 2 Level Sensors, Variable Speed Pneumatic Agitator, Chiller Control Valve, Heat Exchanger
24G959	20gal (75L) Carbon Steel Tank, 2 Level Sensors, Variable Speed Electric Agitator, Chiller Control Valve, Heat Exchanger
24J209	20gal (75L) Stainless Steel Tank, 3 Level Sensors, Insulated
24J707	20gal (75L) Carbon Steel Tank, 3 Level Sensors, Insulated
24J243	2gal (7.6L) Stainless Steel Tank

## Additional Accessories

### Miscellaneous

Part	Description
24C871	Hydraulic Power Pack Hydraulic Tank Fluid Level Sensor
24C873	Hydraulic Power Pack Manifold Oil Temperature Sensor
24P090	Mobile Pallet Base with Casters
24F516	IsoGuard Select fluid, 6 quarts
121728	Extension Cable for Advanced Display Module, 4 meter,
255244	Foot Switch with Guard and 4 meter Cable
24F227	EP and Fusion® Gun Ratio Check
24F235	25 ft hose extensions for L-Head applicator; material, hydraulic, and signal cables
24F236	50 ft hose extensions for L-Head applicator; material, hydraulic, and signal cables
24F237	25 ft hose extensions for S-Head applicator; material, hydraulic, and signal cable
24F238	50 ft hose extensions for S-Head applicator; material, hydraulic, and signal cable
24K206	Nip Sensor Kit
24H019	Air Inlet Filter for Hydraulic Power Pack

### Discrete Gateway Module (DGM)

The HFR Discrete Gateway Module allows the user to control an HFR through multiple external control devices such as contact blocks or relays. The DGM operates in conjunction with the existing Advanced Display Module (ADM) such that both devices can be used to control the machine. See HFR Communication Gateway Module manual for more information

Part	Description
24F843	Single DGM Cube with Board
24F844	Two DGM Cubes with Board
24G830	Single DGM Cube





### Communications Gateway Module (CGM)

The HFR Communication Gateway Module allows the user to control an HFR through an external control device such as a PLC. The DGM operates in conjunction with the existing Advanced Display Module (ADM) such that both devices can be used to control the machine. See HFR Communication Gateway Module manual for more information

Part	Description
24J415	CGM Mounting Kit (Required)
CGMDN0	GCA Gateway Module, DeviceNet Fieldbus
CGMEP0	GCA Gateway Module, EtherNet/IP Fieldbus
CGMPB0	GCA Gateway Module, PROFIBUS Fieldbus
CGMPN0	GCA Gateway Module, PROFINET Fieldbus

# Warnings

The following warnings are for the setup, use, grounding, maintenance, and repair of this equipment. The exclamation point symbol alerts you to a general warning and the hazard symbol refers to procedure-specific risk. Refer back to these warnings. Additional, product-specific warnings may be found throughout the body of this manual where applicable.

 <b>WARNING</b>	
	<p><b>ELECTRIC SHOCK HAZARD</b></p> <p>This equipment must be grounded. Improper grounding, setup, or usage of the system can cause electric shock.</p> <ul style="list-style-type: none"> <li>• Turn off and disconnect power at main switch before disconnecting any cables and before servicing equipment.</li> <li>• Connect only to grounded power source.</li> <li>• All electrical wiring must be done by a qualified electrician and comply with all local codes and regulations.</li> </ul>
	<p><b>TOXIC FLUID OR FUMES HAZARD</b></p> <p>Toxic fluids or fumes can cause serious injury or death if splashed in the eyes or on skin, inhaled, or swallowed.</p> <ul style="list-style-type: none"> <li>• Read MSDSs to know the specific hazards of the fluids you are using.</li> <li>• Store hazardous fluid in approved containers, and dispose of it according to applicable guidelines.</li> <li>• Always wear chemically impermeable gloves when spraying, dispensing, or cleaning equipment.</li> </ul>
	<p><b>PERSONAL PROTECTIVE EQUIPMENT</b></p> <p>You must wear appropriate protective equipment when operating, servicing, or when in the operating area of the equipment to help protect you from serious injury, including eye injury, hearing loss, inhalation of toxic fumes, and burns. This equipment includes but is not limited to:</p> <ul style="list-style-type: none"> <li>• Protective eyewear, and hearing protection.</li> <li>• Respirators, protective clothing, and gloves as recommended by the fluid and solvent manufacturer.</li> </ul>
	<p><b>SKIN INJECTION HAZARD</b></p> <p>High-pressure fluid from dispensing device, hose leaks, or ruptured components will pierce skin. This may look like just a cut, but it is a serious injury that can result in amputation. <b>Get immediate surgical treatment.</b></p> <ul style="list-style-type: none"> <li>• Do not point dispensing device at anyone or at any part of the body.</li> <li>• Do not put your hand over the fluid outlet.</li> <li>• Do not stop or deflect leaks with your hand, body, glove, or rag.</li> <li>• Follow the <b>Pressure Relief Procedure</b> when you stop dispensing and before cleaning, checking, or servicing equipment.</li> <li>• Tighten all fluid connections before operating the equipment.</li> <li>• Check hoses and couplings daily. Replace worn or damaged parts immediately.</li> </ul>

 **WARNING**
**FIRE AND EXPLOSION HAZARD**

Flammable fumes, such as solvent and paint fumes, in **work area** can ignite or explode. To help prevent fire and explosion:

- Use equipment only in well ventilated area.
- Eliminate all ignition sources; such as pilot lights, cigarettes, portable electric lamps, and plastic drop cloths (potential static arc).
- Keep work area free of debris, including solvent, rags and gasoline.
- Do not plug or unplug power cords, or turn power or light switches on or off when flammable fumes are present.
- Ground all equipment in the work area. See **Grounding** instructions.
- Use only grounded hoses.
- Hold gun firmly to side of grounded pail when triggering into pail.
- If there is static sparking or you feel a shock, **stop operation immediately**. Do not use equipment until you identify and correct the problem.
- Keep a working fire extinguisher in the work area.

**PRESSURIZED EQUIPMENT HAZARD**



Fluid from the gun/dispense valve, leaks, or ruptured components can splash in the eyes or on skin and cause serious injury.

- Follow the **Pressure Relief Procedure** when you stop spraying and before cleaning, checking, or servicing equipment.
- Tighten all fluid connections before operating the equipment.
- Check hoses, tubes, and couplings daily. Replace worn or damaged parts immediately.

**EQUIPMENT MISUSE HAZARD**





Misuse can cause death or serious injury.

- Do not operate the unit when fatigued or under the influence of drugs or alcohol.
- Do not exceed the maximum working pressure or temperature rating of the lowest rated system component. See **Technical Data** in all equipment manuals.
- Use fluids and solvents that are compatible with equipment wetted parts. See **Technical Data** in all equipment manuals. Read fluid and solvent manufacturer's warnings. For complete information about your material, request MSDS from distributor or retailer.
- Do not leave the work area while equipment is energized or under pressure. Turn off all equipment and follow the **Pressure Relief Procedure** when equipment is not in use.
- Check equipment daily. Repair or replace worn or damaged parts immediately with genuine manufacturer's replacement parts only.
- Do not alter or modify equipment.
- Use equipment only for its intended purpose. Call your distributor for information.
- Route hoses and cables away from traffic areas, sharp edges, moving parts, and hot surfaces.
- Do not kink or over bend hoses or use hoses to pull equipment.
- Keep children and animals away from work area.
- Comply with all applicable safety regulations.



 <b>WARNING</b>	
	<p><b>MOVING PARTS HAZARD</b> Moving parts can pinch, cut or amputate fingers and other body parts.</p> <ul style="list-style-type: none"> <li>• Keep clear of moving parts.</li> <li>• Do not operate equipment with protective guards or covers removed.</li> <li>• Pressurized equipment can start without warning. Before checking, moving, or servicing equipment, follow the <b>Pressure Relief Procedure</b> and disconnect all power sources.</li> </ul>
	<p><b>BURN HAZARD</b> Equipment surfaces and fluid that's heated can become very hot during operation. To avoid severe burns:</p> <ul style="list-style-type: none"> <li>• Do not touch hot fluid or equipment.</li> </ul>

## Important Two-Component Material Information



### Isocyanate Conditions

						
<p>Spraying or dispensing materials containing isocyanates creates potentially harmful mists, vapors, and atomized particulates.</p> <p>Read material manufacturer's warnings and material MSDS to know specific hazards and precautions related to isocyanates.</p> <p>Prevent inhalation of isocyanate mists, vapors, and atomized particulates by providing sufficient ventilation in the work area. If sufficient ventilation is not available, a supplied-air respirator is required for everyone in the work area.</p> <p>To prevent contact with isocyanates, appropriate personal protective equipment, including chemically impermeable gloves, boots, aprons, and goggles, is also required for everyone in the work area.</p>						

### Keep Components A (Red) and B (Blue) Separate

						
<p>Cross-contamination can result in cured material in fluid lines which could cause serious injury or damage equipment. To prevent cross-contamination of the equipment's wetted parts, <b>never</b> interchange component A (Red) and component B (Blue) parts.</p>						

### Material Self-ignition

						
<p>Some materials may become self-igniting if applied too thickly. Read material manufacturer's warnings and material MSDS.</p>						

## Moisture Sensitivity of Isocyanates

Isocyanates (ISO) are catalysts used in two component foam and polyurea coatings. ISO will react with moisture (such as humidity) to form small, hard, abrasive crystals, which become suspended in the fluid. Eventually a film will form on the surface and the ISO will begin to gel, increasing in viscosity. If used, this partially cured ISO will reduce performance and the life of all wetted parts.

**NOTE:** The amount of film formation and rate of crystallization varies depending on the blend of ISO, the humidity, and the temperature.

To prevent exposing ISO to moisture:

- Always use a sealed container with a desiccant dryer in the vent, or a nitrogen atmosphere. **Never** store ISO in an open container.
- Keep the IsoGuard Select cylinder filled with IsoGuard Select, part 24F516. The lubricant creates a barrier between the ISO and the atmosphere.
- Use moisture-proof hoses specifically designed for ISO, such as those supplied with your system.
- Never use reclaimed solvents, which may contain moisture. Always keep solvent containers closed when not in use.

## A (Red) and B (Blue) Components

### IMPORTANT!

Material suppliers can vary in how they refer to plural component materials.

Be aware that when standing in front of the manifold on proportioner:

- Component A (Red) is on the left side.
- Component B (Blue) is on the right side.

- Never use solvent on one side if it has been contaminated from the other side.
- Always lubricate threaded parts with ISO pump oil or grease when reassembling.

## Foam Resins with 245 fa Blowing Agents

Some foam blowing agents will froth at temperatures above 90°F (33°C) when not under pressure, especially if agitated. To reduce frothing, minimize preheating in a circulation system.

## Changing Materials

- When changing materials, flush the equipment multiple times to ensure it is thoroughly clean.
- Always clean the fluid inlet strainers after flushing.
- Check with your material manufacturer for chemical compatibility.
- Most materials use ISO on the A (Red) side, but some use ISO on the B (Blue) side. See the following section.

For all machines:

- The A (Red) side is intended for ISO, hardeners, and catalysts.
- If one of the materials is moisture-sensitive that material should always be on the A (Red) side.
- The B (Blue) side is intended for polyols, resins, and bases.

**NOTE:** For machines with material volume ratios other than 1:1, the higher volume side is typically the B (Blue) side.



# Shutdown



## 1. Park pumps.

- a. From the Home screen, press  and select Standby mode.

- b. Press . Material will dispense. Pump will park automatically. Once pump is parked, pump will stop moving.

**If a dispense gun with a trigger is installed,** pulling the trigger will begin a park operation. Material will dispense. Continue pulling the trigger until the pump stops moving.

2. Press the power key on the ADM 
3. Turn main power switch (MP) to OFF position.
4. Close A (Red) and B (Blue) side fluid supply valves (FV).

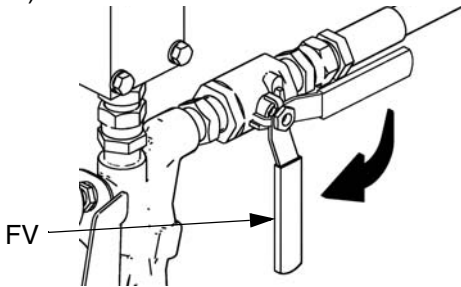

ti9883a1

5. Perform **Pressure Relief Procedure** on page 22.
6. Shut down feed pumps as required. See feed pump manual.

# Pressure Relief Procedure



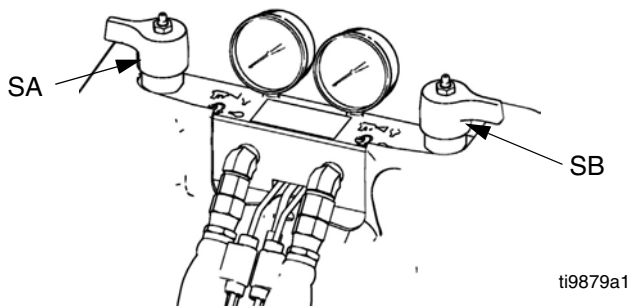

1. Shut off feed pumps and agitator, if used.
2. Turn PRESSURE RELIEF/DISPENSE valves (SA, SB) to PRESSURE RELIEF/CIRCULATION . Route fluid to waste containers or supply tanks. Ensure gauges drop to 0.



3. **For models with an EP Gun installed,** engage gun safety lock.
4. Relieve pressure in EP Gun or dispense valve. See related manual.

# Flushing

						
<p>Flush equipment only in a well-ventilated area. Do not dispense flammable fluids. Do not turn on heaters while flushing with flammable solvents.</p>						

- Flush out old fluid with new fluid, or flush out old fluid with a compatible solvent before introducing new fluid.
- Use the lowest possible pressure when flushing.
- All fluid components are compatible with common solvents. Use only moisture-free solvents. See **Technical Data** on page 92 for wetted components. See solvent manufacturers information for material compatibility.
- To flush feed hoses, pumps, and heaters separately from heated hoses, set PRESSURE RELIEF/DIS-PENSE valves (SA, SB) to PRESSURE

RELIEF/CIRCULATION . Flush through bleed lines (N).

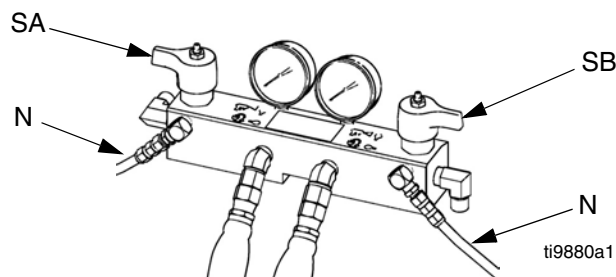

- To flush entire system, circulate through gun fluid manifold (with manifold removed from gun).
- To prevent moisture from reacting with isocyanate, always leave the system dry or filled with a moisture-free plasticizer or oil. Do not use water. See **Important Two-Component Material Information** on page 19.

# Repair

## Pumpline

See Z-Series Chemical Pumps manual, HFR Hydraulic Driver manuals for more detailed pumpline repair information.

### Remove Chemical Pumps



This procedure removes the chemical pumps so that replacement parts can be installed. See Z-Series Chemical Pumps manual for replacement parts installation procedure.

1. **For models with heat**, turn off all heat including heated hoses and primary heaters.
2. Flush system, see page 23.
3. Perform **Shutdown**, see page 21.
4. Remove the front pump shroud.

5. Disconnect the chemical pump inlet and outlet fluid lines. Do not disconnect the fluid manifold inlet line or the fluid line connections at the heater.

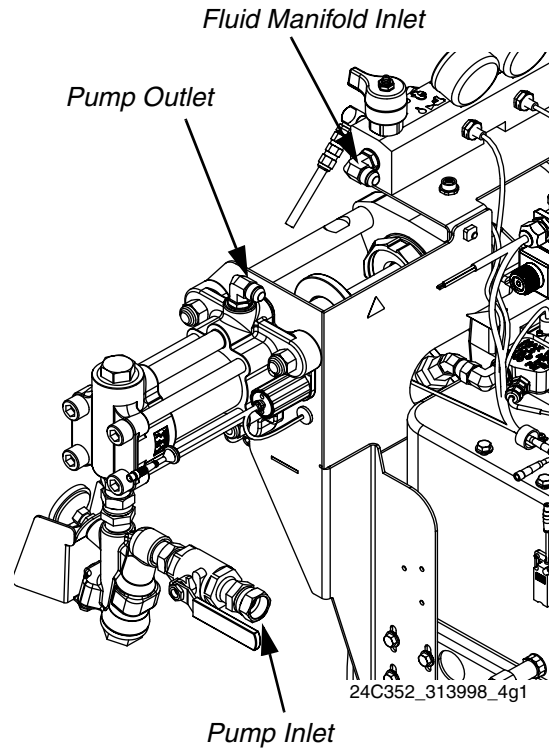

6. Unthread smaller cylinder from hydraulic driver and slide inside larger cylinder. Use punch slots in lube cylinder to aid rotation if necessary. See FIG. 1.

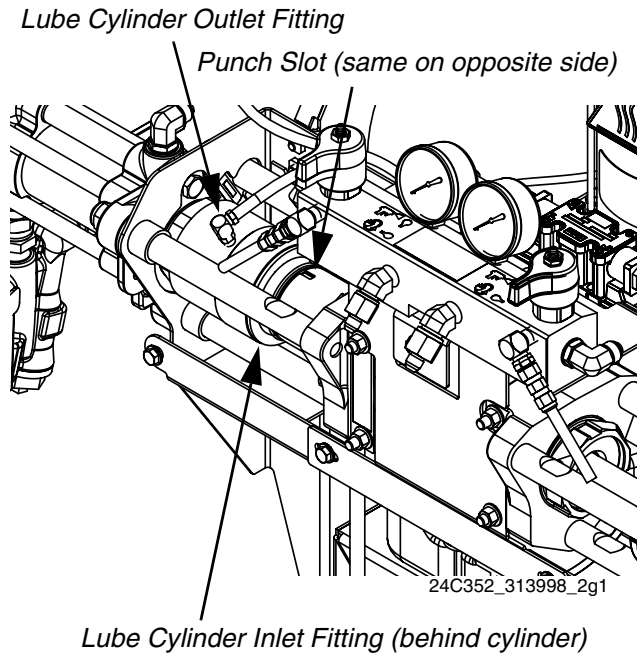

**FIG. 1: Lube Cylinder**

8. Remove coupler from the A and B side pump shafts. See FIG. 2.
9. Unscrew LVDT sensor assembly and spool assembly from pump outlet housing. Wipe off spool assembly. See FIG. 2.
10. Remove three nuts securing pump to tie rods. See FIG. 2.

7. Remove two shoulder bolts from LVDT collar then remove collar from B side pump shaft. See FIG. 2.

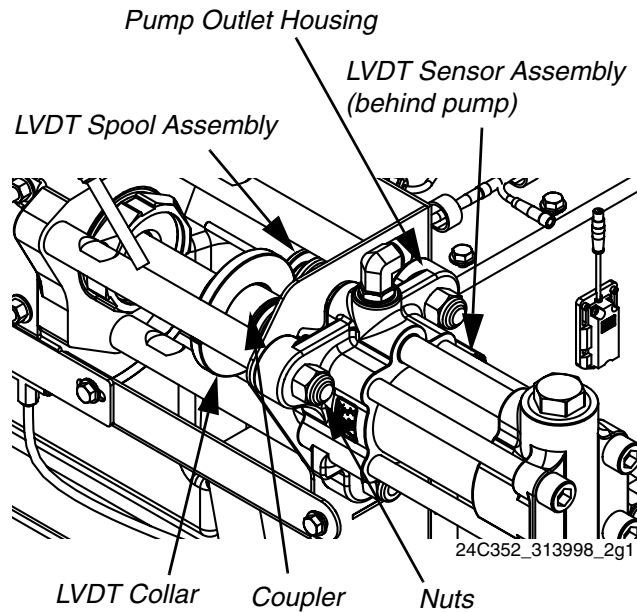

**FIG. 2**

## Install Chemical Pumps

Reconnect or install a different size chemical pump to achieve desired ratio.

1. Install ISO lube cylinder on A side pump. Apply light coating of lubricant on o-rings on outside of small cylinder.
2. Install nuts on tie rods after the pumps have been installed. Torque to 50-60 ft-lb (68-81 N•m).
3. Install coupler on A and B side pump shafts.
4. Install LVDT Assembly.
  - a. Apply a very light coat of hydraulic oil on LVDT sensor tube and install through pump outlet housing. Install spool assembly.
  - b. Install LVDT collar on coupler and pump shaft. Ensure that the split on the LVDT collar does not ride in the spool assembly.
  - c. Apply thread sealant to shoulder bolts then install in LVDT collar. Torque to 40-50 in-lb (4.5-5.6 N•m).
5. After the IsoGuard Select cylinder has been installed on the A side pump, apply pipe sealant on cylinder outlet fitting.
6. Perform **Prime IsoGuard Select® Cylinder** procedure, see page 26.
7. Reconnect inlet and outlet fluid lines.

## Prime IsoGuard Select® Cylinder

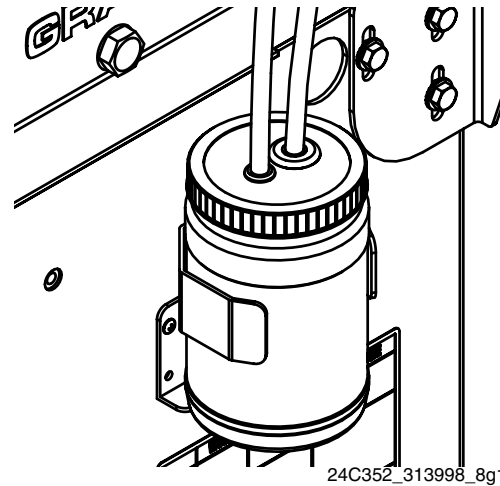
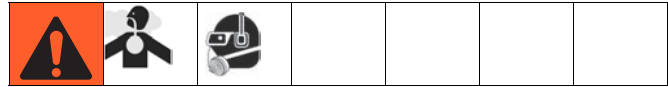
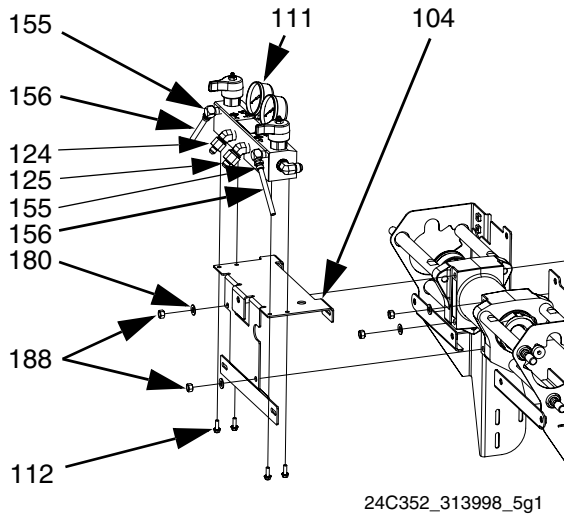

**FIG. 3: IsoGuard Select System**

Ensure that the IsoGuard Select cylinder outlet faces upward for air to exhaust.

1. Install IsoGuard Select cylinder inlet fitting and inlet tube into bottom of cylinder. The inlet tube is the tube with a check valve installed in it which points in the direction of flow towards the IsoGuard Select cylinder.
2. Install IsoGuard Select cylinder outlet fitting and outlet tube into top of cylinder. The outlet tube is the tube with a check valve installed in it which points in the direction of flow away from the IsoGuard Select cylinder.
3. Remove check valve from end of outlet tube.
4. Use funnel to pour IsoGuard Select (24F516) into tube to fill cylinder.
5. With check valve arrow pointing away from the IsoGuard Select cylinder, install check valve in end of outlet tube.
6. Install tubes into reservoir and install reservoir into holder.

## Remove HFR Hydraulic Driver

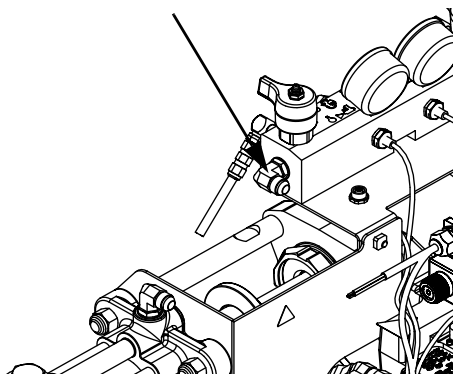

**FIG. 4**

This procedure removes the HFR Hydraulic Driver so replacement parts can be installed. See HFR Hydraulic Driver manual for replacement parts installation procedure.

1. Perform **Remove Chemical Pumps** procedure, see page 24.
2. Disconnect the fluid manifold inlet lines. Do not disconnect the fluid line connections at the heater.

*Fluid Manifold Inlet*



3. Remove pump support brackets. Each bracket is secured with three screws at the base frame and two screws at the manifold bracket.

4. See FIG. 4. Remove four nuts (188) securing hydraulic driver to hydraulic power pack. This will also loosen manifold plate (104) from hydraulic driver. Remove manifold plate. Remove hydraulic driver.

## Install HFR Hydraulic Driver

This procedure installs the hydraulic driver after replacement parts have been installed and actuator has been reassembled. See HFR Hydraulic Driver manual for replacement parts installation procedure.

1. Hang the hydraulic driver on the studs. Verify o-rings between driver and hydraulic power pack are installed and lubricated. Secure the driver with nuts and washer at bottom-left and top-right corners.
2. Install manifold bracket. Secure at top-left and bottom-right corners.
3. Install pump support brackets, torque to 300 in-lb (33.9 N•m). This will also install manifold plate (104) to hydraulic driver.
4. Connect fluid manifold inlet lines.
5. Perform **Install Chemical Pumps** procedure, see page 26.

## Remove PowerHouse Pumpline



The Hydraulic Power Pack must be removed to perform some Hydraulic Power Pack repair procedures. In order to remove the Hydraulic Power Pack, the PowerHouse pumpline must be removed. See **Hydraulic Power Pack Repair** starting on page 32 for more information.

1. Perform **Shutdown** procedure, see page 21.
2. Flush the system, see page 23.
3. Disconnect the chemical pump inlet, pump outlet, and fluid manifold inlet lines. Do not disconnect the fluid line connections at the heater.

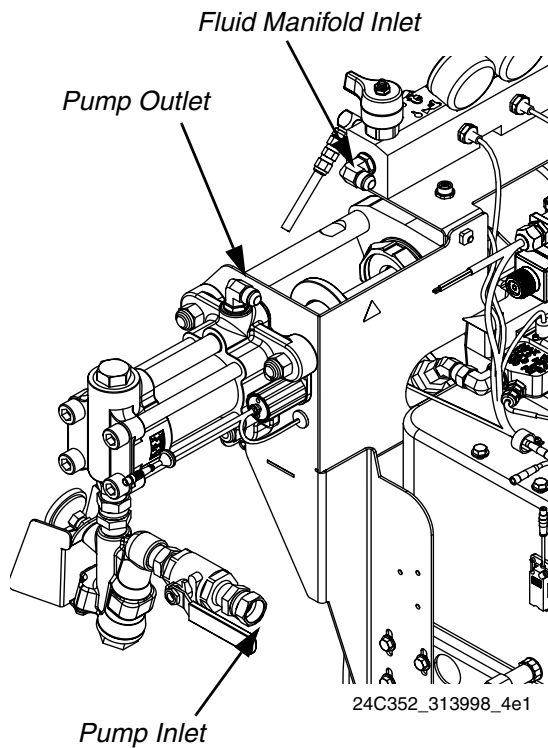

4. Remove lube cylinder inlet and outlet fittings. Let cylinder drain.

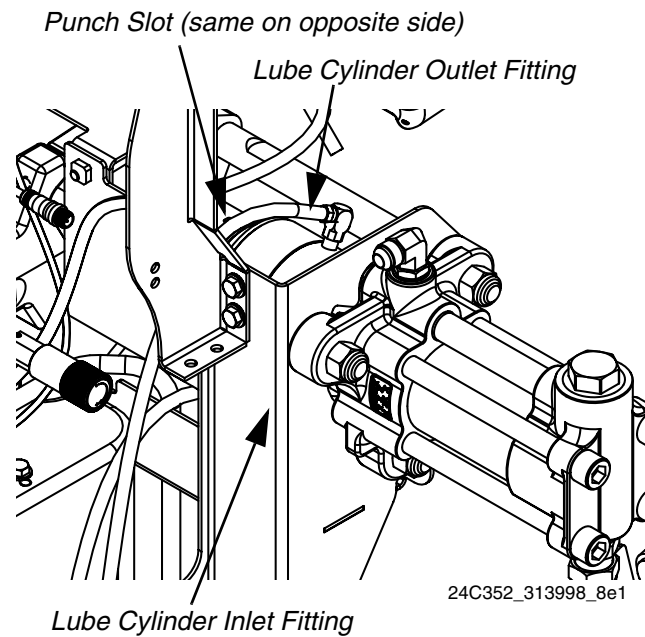

**FIG. 5: Lube Cylinder, Viewed from Rear Left of Machine**

5. See FIG. 6. Remove four screws (107) securing pumpline to hydraulic power pack. This will also loosen manifold plate (104) from hydraulic driver.

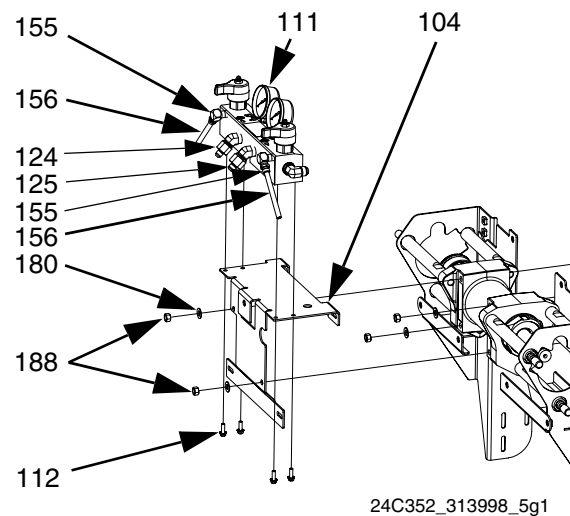

**FIG. 6**



6. While supporting the pumpline, remove the three bolts on each side of the machine securing the pump support brackets to the machine base. See FIG. 7. Remove pumpline.

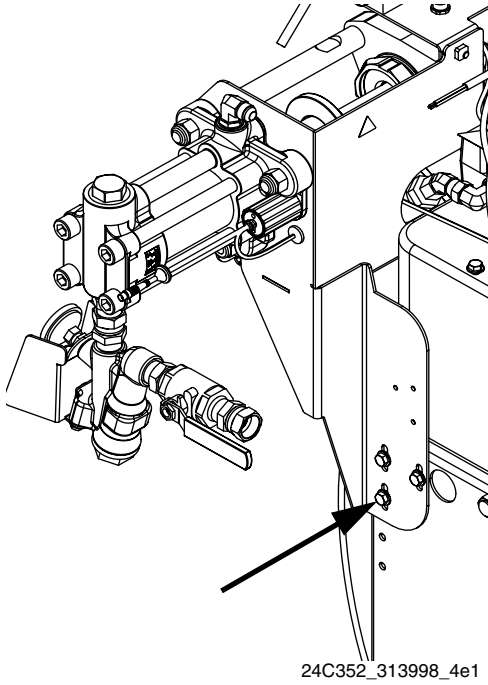

**FIG. 7**

---

## Install PowerHouse Pumpline

The Hydraulic Power Pack must be removed to perform some Hydraulic Power Pack repair procedures. In order to remove the Hydraulic Power Pack, the PowerHouse pumpline must be removed. This procedure is for installing the PowerHouse pumpline at the end of the Hydraulic Power Pack Repair procedure. See **Hydraulic Power Pack Repair** starting on page 32 for more information.

1. While supporting the pumpline, install the three bolts on each side of the machine securing the pump support brackets to the machine base. See FIG. 7. Torque to 150 in-lb (16.9 N•m).
2. See FIG. 6. Align manifold plate (104) with hydraulic driver. Align hydraulic driver with hydraulic power pack. Install four screws (107) securing hydraulic driver to hydraulic power pack. This will also install manifold plate (104) to hydraulic driver. Torque to 300 in-lb (33.9 N•m).
3. Install lube cylinder inlet and outlet fittings. See FIG. 5. Apply thread sealant to threads.
4. Perform **Prime IsoGuard Select® Cylinder** procedure, see page 26.
5. Connect the chemical pump inlet, pump outlet, and fluid manifold inlet lines.

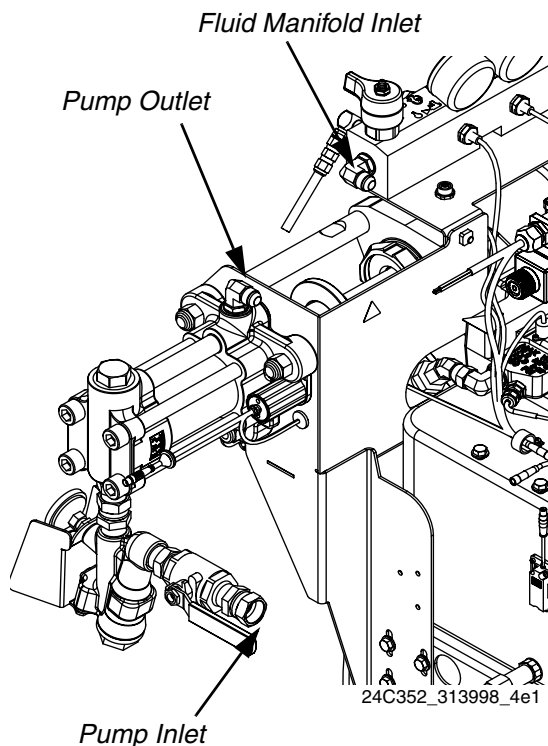



# Hydraulic Power Pack Repair

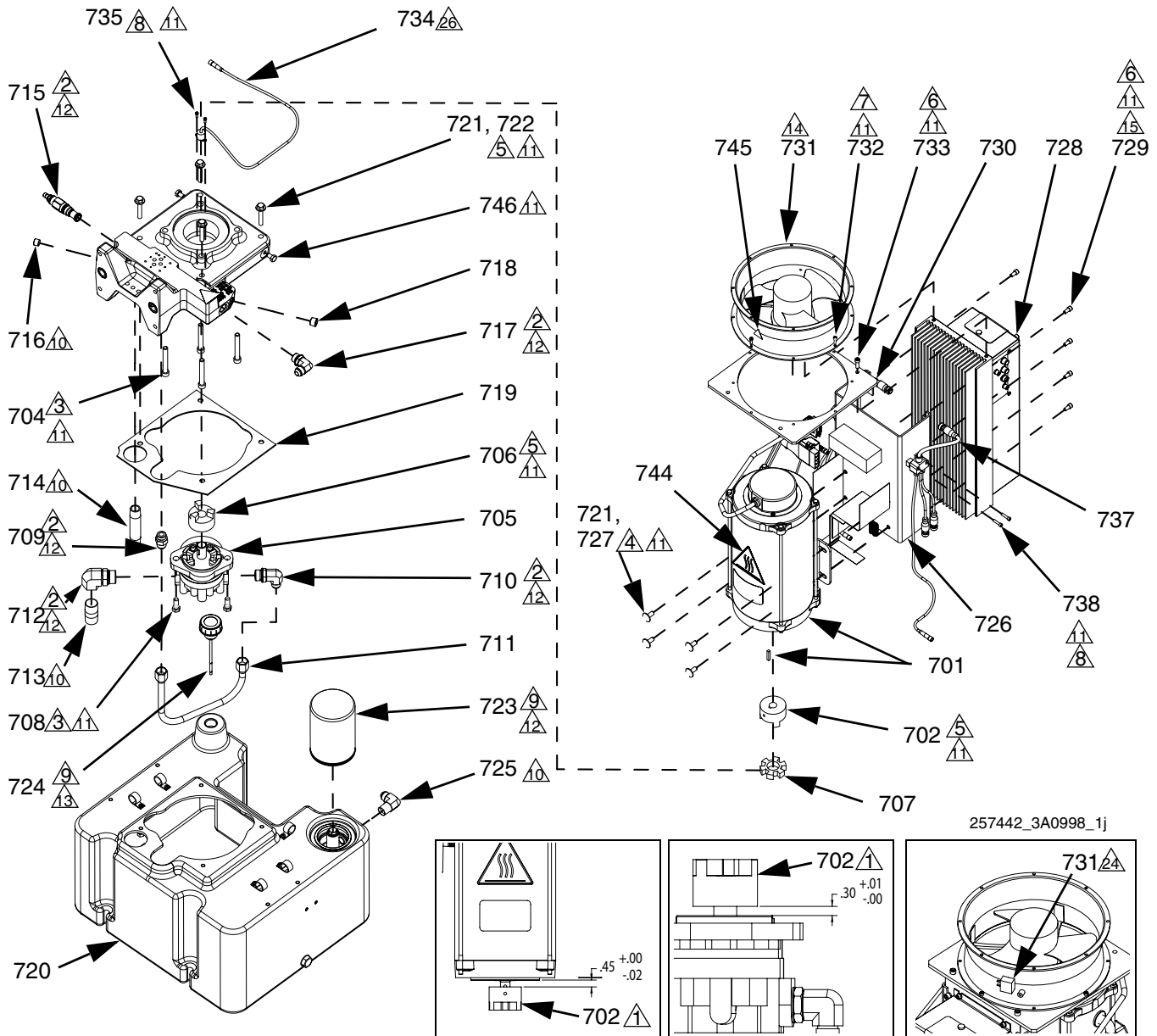

- Assemble coupler to specified dimensions prior to mounting assembly to housing.
- Torque to 40 ft-lb (54 N•m).
- Torque to 35 ft-lb (47 N•m).
- Torque to 20 ft-lb (27 N•m).
- Torque to 15 ft-lb (20 N•m).
- Torque to 10 ft-lb (14 N•m).
- Torque to 58 in-lb (6.5 N•m).

- Torque to 34 in-lb (3.8 N•m).
- Torque 1/4 turn past hand-tight.
- Apply PTFE tape on installation end only.
- Apply medium strength threadlocker prior to assembly.
- Apply light coating of lubricant to seals.
- Fill reservoir with hydraulic fluid.

- Orient with airflow arrow pointing toward mounting bracket.
- Prior to installing Ref. 728 into Ref. 726, install Ref. 729 into Ref. 728 and adjust head 1/8 in. from surface.
- Align fan plug as shown.
- Apply thermal lubricant to contact side.

**Fig. 8: Hydraulic DC Power Pack**

## Remove Hydraulic Power Pack Shroud

1. Remove four screws from base of shroud.
2. Lift shroud off of Hydraulic Power Pack.

## Install Hydraulic Power Pack Shroud

### NOTICE

Do not over-torque any item that threads into the hydraulic tank. This will strip the threads and require tank replacement.

1. Place shroud on top of Hydraulic Power Pack.
2. Install four screws securing shroud to hydraulic tank.

## Replace Hydraulic Filter

Filter is located at right rear of hydraulic power pack. See FIG. 8 on page 32.

### NOTICE

If any debris falls into the hydraulic tank, the debris must be removed or machine damage will result.

1. Perform **Shutdown** procedure, see page 21.
2. Use compressed air to remove any loose debris around the hydraulic filter.
3. Remove new filter from wrapping.
4. Apply a light coat of hydraulic fluid to the o-ring on the face of the hydraulic filter.
5. Being careful not to allow any debris into the hydraulic tank remove old filter from tank then quickly install new filter.

## Replace Fan

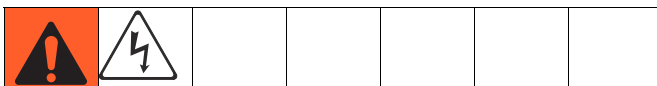

See FIG. 8 on page 32.

1. Perform **Shutdown** procedure, see page 21.
2. **Remove Hydraulic Power Pack Shroud**, see procedure on this page.

3. Remove four screws (732) connecting fan to mounting plate.
4. Remove fan and install new fan.
5. Install four screws (732) connecting fan to Motor and Motor Control Module.
6. **Install Hydraulic Power Pack Shroud**, see procedure on this page.

## Remove Motor Control Module



See FIG. 8 on page 32.

1. Perform **Shutdown** procedure, see page 21.
2. **Remove Hydraulic Power Pack Shroud**, see procedure on this page.
3. Remove four screws (732) connecting fan to Motor and Motor Control Module. Remove fan and mounting plate.
4. Note the location of each Motor Control Module cable then remove all electrical cables on the left and right sides of the Motor Control Module.
5. Remove six screws (729) securing Motor Control Module in place.
6. Slowly and carefully slide the Motor Control Module up until the cable on the bottom of the Motor Control Module can be accessed and removed. Disconnect the cable.
7. Slide the Motor Control Module up and remove.

## Adjust Motor Control Module Selector Switch

### NOTICE

If the Motor Control Module is replaced, the selector switch must be set prior to initial startup of the Motor Control Module or damage may occur.

The Motor Control Module uses an 8-position selector switch (S) to set system maximum working pressure. See FIG. 9.

The system can be configured to run in two pressure ranges:



- **0-3000 psi (0-20.7 MPA, 0-207 bar):** For systems with all components rated to 3000 psi maximum working pressure or higher.
- **0-2000 psi (0-13.8 MPA, 0-138 bar):** For systems with one or more component rated less than 3000 psi maximum working pressure. For example, if the dispense valve is rated to 2500 psi, then the 0-2000 psi range must be used.

**NOTE: The Motor Control Module selector switch (S) position #1 sets the system to 2000 psi maximum working pressure. Selector switch position #3 sets the system to 3000 psi maximum working pressure.**

The factory setting for the Motor Control Module selector switch is position #1 to set the machine to 2000 psi if the machine is shipped with no hoses or hoses rated to 2000 psi maximum working pressure. If the machine is shipped with hoses rated to 3000 psi maximum working pressure or higher then the factory setting for the selector switch is position #3 to set the machine to 3000 psi.

The selector switch position will be properly set at the factory for new systems. When a motor control module is replaced, the selector switch must be set to the correct setting by the user prior to initial startup.

To change the maximum working pressure rating of the system in the field, all outlet components including hoses and dispense valve must be rated at or above the new system maximum working pressure rating. For example, if the new system rating will be 3000 psi, all system components must be rated to at least 3000 psi maximum working pressure.

							
<ul style="list-style-type: none"> <li>• Do not install components rated to less than the highest pressure in the selected pressure range. For example, if the 0-2000 psi range is selected do not install items rated less than 2000 psi. If the 0-3000 psi range is selected do not install items rated less than 3000 psi. Doing so may lead to overpressurization and ruptured components.</li> <li>• High-pressure fluid from ruptured components will pierce skin. This may look like just a cut, but it is a serious injury that can result in amputation. <b>Get immediate surgical treatment.</b></li> </ul>							

To set the Motor Control Module selector switch:

1. Turn machine power off.
2. Remove the access cover (D). See FIG. 9.
3. Set the selector switch (S).
4. Install access cover (D).

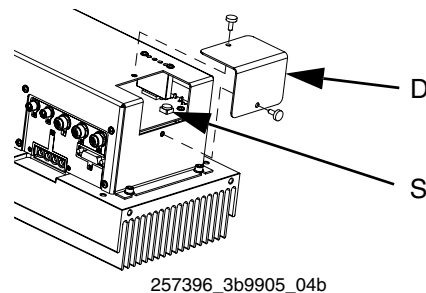
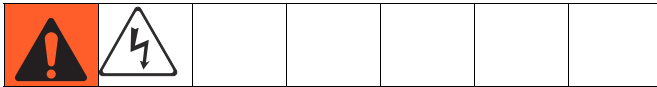

FIG. 9

## Install Motor Control Module



This procedure starts assuming that the old Motor Control Module is removed from the machine. See **Remove Motor Control Module** procedure, see page 33.

See FIG. 8 on page 32.

1. Perform **Adjust Motor Control Module Selector Switch** procedure on page 34.

### NOTICE

Motor Control Module selector switch position must be set prior to startup of Motor Control Module or damage may occur.

2. Slide the Motor Control Module into the slot.
3. Attach the cable on the bottom of the Motor Control Module.
4. Install the six screws (729) securing Motor Control Module in place.
5. Install electrical cables on left and right sides of the Motor Control Module.
6. Install four screws (732) connecting fan to Motor and Motor Control Module. Install fan and mounting plate.
7. **Install Hydraulic Power Pack Shroud**, see procedure on page 33.

## Remove Hydraulic Power Pack



The hydraulic power pack weighs up to 300 lb. To avoid serious injury due the hydraulic power pack falling, secure the hydraulic lift when raising the hydraulic power pack.

### NOTICE

If any debris falls into the hydraulic tank, the debris must be removed or machine damage will result.

This procedure removes the hydraulic power pack from the machine as a single unit to enable further disassembly. User must purchase three 5/16-18 eye-bolts capable of holding 300 lb to perform this procedure.

See FIG. 8 on page 32.

1. Perform **Shutdown** procedure, see page 21.
2. Perform **Remove Hydraulic Power Pack Shroud**, see procedure on page 33.
3. Perform **Remove Motor Control Module** procedure, see page 33.
4. Perform **Remove PowerHouse Pumpline** procedure, see page 28.
5. Disconnect heat exchanger inlet hose and fitting from elbow fitting (617). Disconnect heat exchanger outlet hose and fitting from elbow fitting (025).
6. Remove the two bolts (746) from the fluid housing (703) and replace each with a strong 5/16-18 thread eye-bolt. Install a third strong 5/16-18 eye-bolt as indicated. See FIG. 10. See FIG. 8 on page 32 for full hydraulic power pack view.

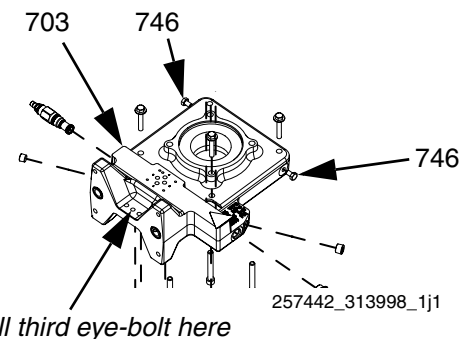

FIG. 10

7. Run a rope through the three eye-bolts and between the motor and the Motor Control Module. Secure to a hydraulic lift.
8. Remove the four bolts (604) and washers (603) securing the tank to the electrical enclosure. See **Power Pack Module** on page 52.
9. Lift the hydraulic power pack and place on a sturdy location capable of supporting up to 300 lbs.

## Install Hydraulic Power Pack



### NOTICE

If any debris falls into the hydraulic tank, the debris must be removed or machine damage will result.

### NOTICE

Do not over-torque any item that threads into the hydraulic tank. This will strip the threads and require tank replacement.

This procedure assumes the Hydraulic Power Pack has been removed from the machine and is assembled except for the Motor Control Module.

See FIG. 8 on page 32.

1. Run a rope through the three eye-bolts and between the Motor and the Motor Control Module. Secure to a hydraulic lift.
2. Lift the Hydraulic Power Pack and place onto the electronic enclosure.
3. Align the holes with the tank then install finger-tight the four bolts (604) and washers (603) securing the tank to the electrical enclosure. Torque to 10 ft-lb (14 N•m).
4. Remove rope and lift.
5. Remove eye-bolts. Install original bolts (746) into fluid housing (703). See FIG. 10.
6. Perform **Install PowerHouse Pumpline** procedure, see page 30.
7. Perform **Install Motor Control Module** procedure, see page 35.
8. Connect heat exchanger inlet hose and fitting to elbow fitting (617). Connect heat exchanger outlet hose and fitting to elbow fitting located on rear right face of tank. See **Power Pack Module** on page 52.

## Replace Tank Gasket, Tank



See FIG. 8 on page 32.

1. Perform **Remove Hydraulic Power Pack** procedure, see page 35.
2. Remove hex head cap screws (722) securing hydraulic housing (703) to tank (720). Carefully remove motor (701) and hydraulic housing assembly from tank.
3. Remove tank gasket. If tank is damaged, replace tank.

### NOTICE

Do not over-torque any item that threads into the hydraulic tank. This will strip the threads and require tank replacement.

4. Install thrust washers (721) onto hex head cap screws (022). Apply pipe sealant to threads of screws. Align tank gasket (719), hydraulic housing, and tank (720) then install screws. Torque to 15 ft-lb (20 N•m).
5. Perform **Install Hydraulic Power Pack** procedure, see page 36.

## Remove Motor



See FIG. 8 on page 32.

1. Perform **Remove Hydraulic Power Pack** procedure, see page 35.
2. Remove four hex head cap screws (722) securing hydraulic housing (703) and motor (701) to tank (020). Carefully remove motor and hydraulic housing assembly from tank.
3. Remove four hex head cap screws (727) connecting mounting bracket (726) to motor.
4. Remove four socket head cap screws (704) securing motor to hydraulic housing. Carefully remove motor from hydraulic housing.



- Loosen set screw for motor coupler (702) then remove motor coupler.

### Install Motor



See FIG. 8 on page 32.

- Use four hex head cap screws (727) and thrust washers (721) to install Motor Control Module mounting bracket (726) onto motor (701).
- Install motor coupler (702) onto motor (701). Coupler must be 0.65-0.67 in. from the face of the motor. Torque motor coupler set screw to 15 ft-lb (20 N•m).
- Install spider coupler (707) into motor coupler.
- Use four socket head cap screws (704) to attach hydraulic housing (703) to motor. Be sure to align teeth of gear coupler with the teeth of the motor coupler. Apply pipe sealant to threads of screws. Torque to 35 ft lb (47 N•m).

#### NOTICE

Do not over-torque any item that threads into the hydraulic tank. This will strip the threads and require tank replacement.

- Install thrust washers (721) onto hex head cap screws (722). Apply pipe sealant to threads of screws. Align tank gasket (719), hydraulic housing, and tank (720) then install screws. Torque to 15 ft-lb (20 N•m).
- Perform **Install Hydraulic Power Pack** procedure, see page 36.

### Remove Hydraulic Gear Pump



See FIG. 8 on page 32.

- Perform **Remove Hydraulic Power Pack** procedure, see page 35.
- Remove hex head cap screws (722) securing hydraulic housing (703) to tank. Carefully remove motor (701) and hydraulic housing assembly.
- Remove tube (711).
- Remove elbow fittings (710, 712) from gear pump (705).
- Remove two hex head cap screws (708) securing gear pump to hydraulic housing.
- Remove spider coupler (707).
- Loosen set screw for gear coupler (706) then remove gear coupler from gear pump.

### Install Hydraulic Gear Pump



See FIG. 8 on page 32.

- Install gear coupler (706) onto gear pump (705). Coupler must be 0.12 to 0.13 in. from the face of the gear pump. Torque gear coupler set screw to 15 ft-lb (20 N•m).
- Install spider coupler (707) into gear coupler.
- Use two hex head cap screws (708) to attach gear pump to hydraulic housing. Be sure to align teeth of gear coupler with the teeth of the motor coupler. Torque screws to 35 ft-lb (47 N•m).
- Apply a light coat of lubricant to seals of elbow fittings (710, 712). Install elbow fittings into gear pump. See FIG. 8 on page 32. for fitting alignment. Torque both fittings to 40 ft-lb (54 N•m).

5. Apply a light coating of lubricant to seals of tube (711). Install tube (711) onto elbow fitting (710) and straight fitting (709). Hand-tighten then use wrench to tighten 90 degrees further.

**NOTICE**

Do not over-torque any item that threads into the hydraulic tank. This will strip the threads and require tank replacement.

6. Install thrust washers (721) onto hex head cap screws (722). Apply pipe sealant to threads of screws. Align tank gasket (719), hydraulic housing, and tank (720) then install screws. Torque to 15 ft-lb (20 N•m).
7. Perform **Install Hydraulic Power Pack** procedure, see page 36.

# Parts

## Base Machine

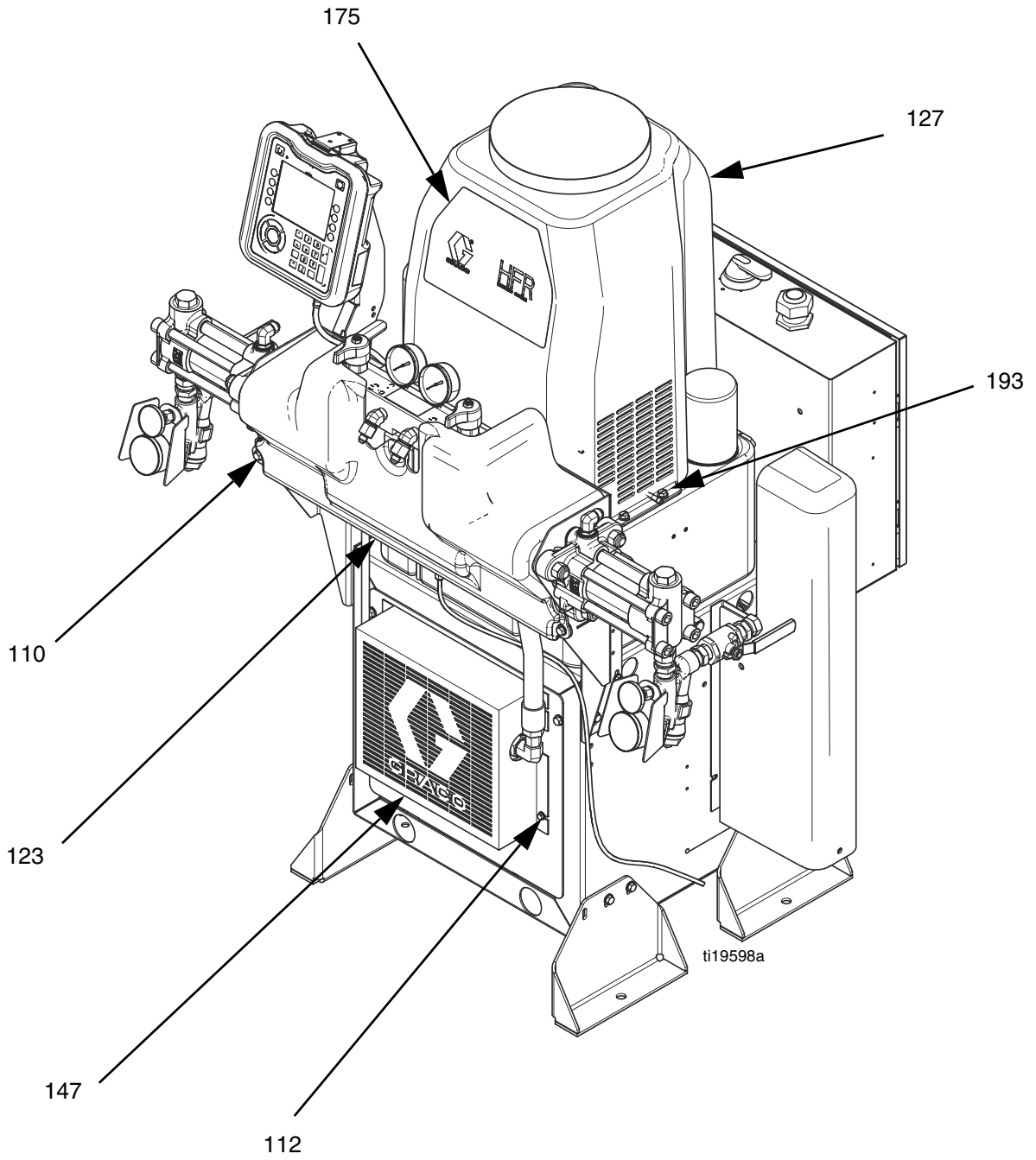

FIG. 11: Base Machine, Image 1 of 6

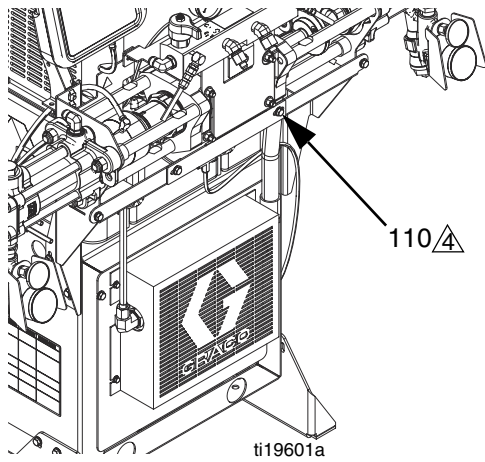
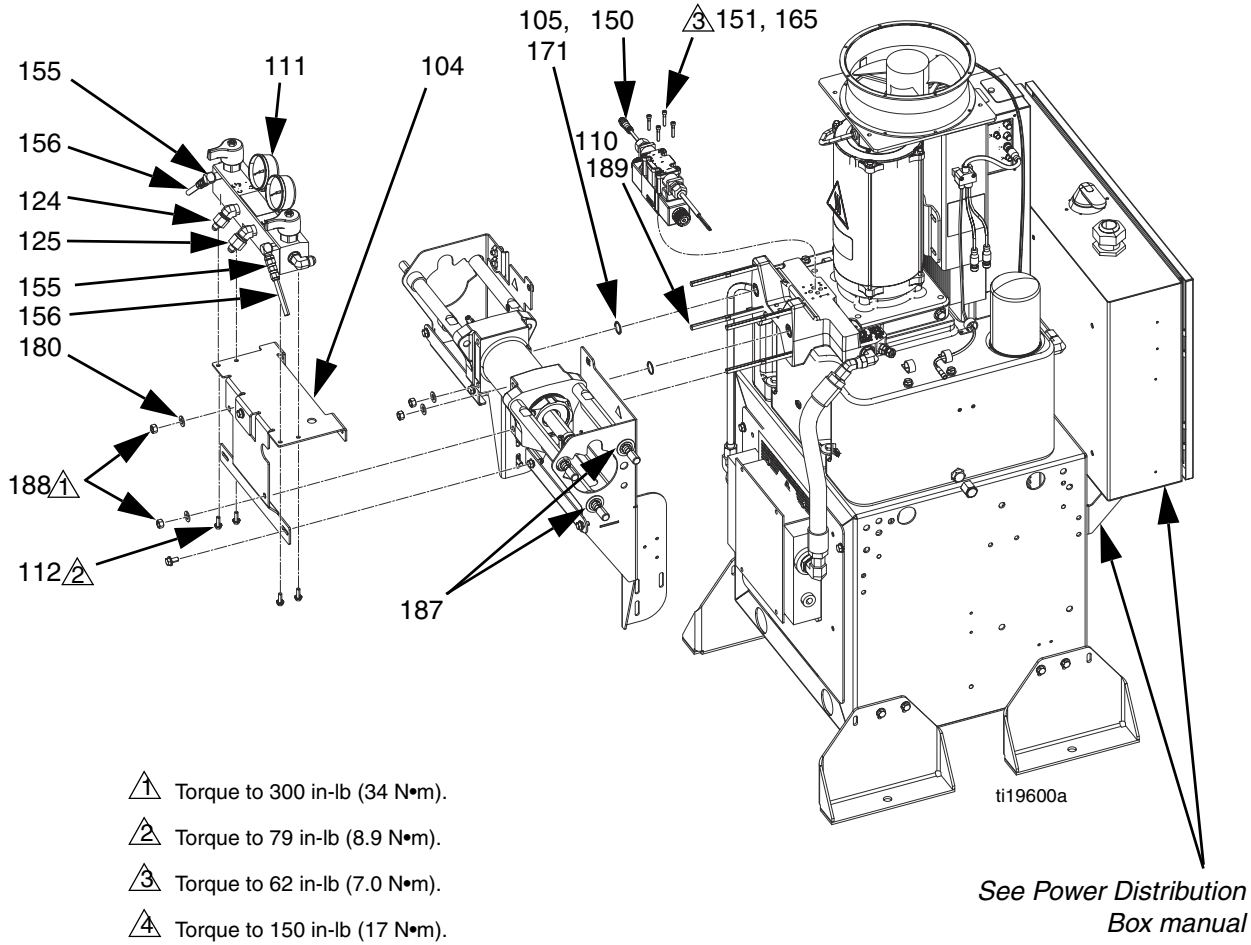
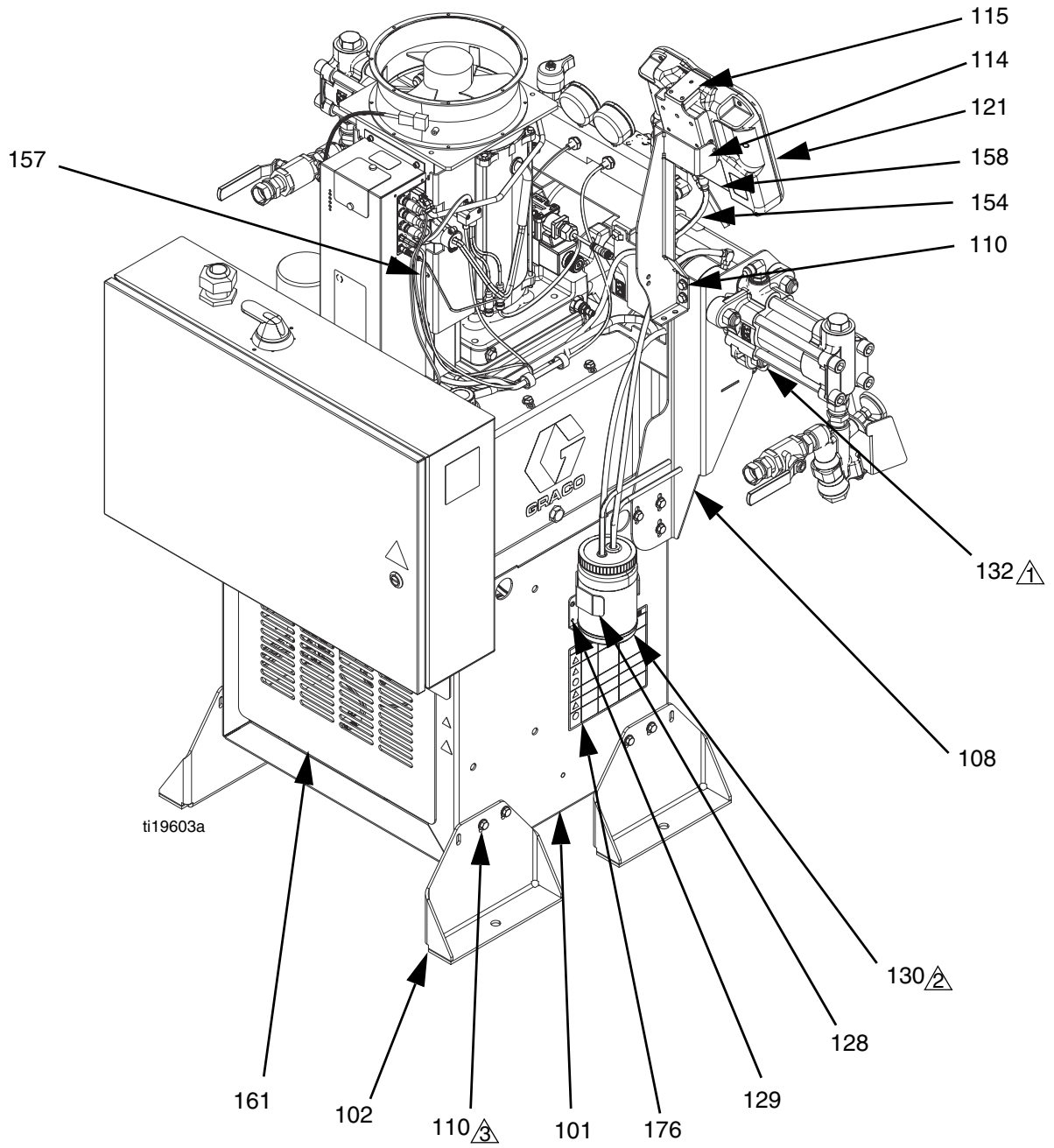
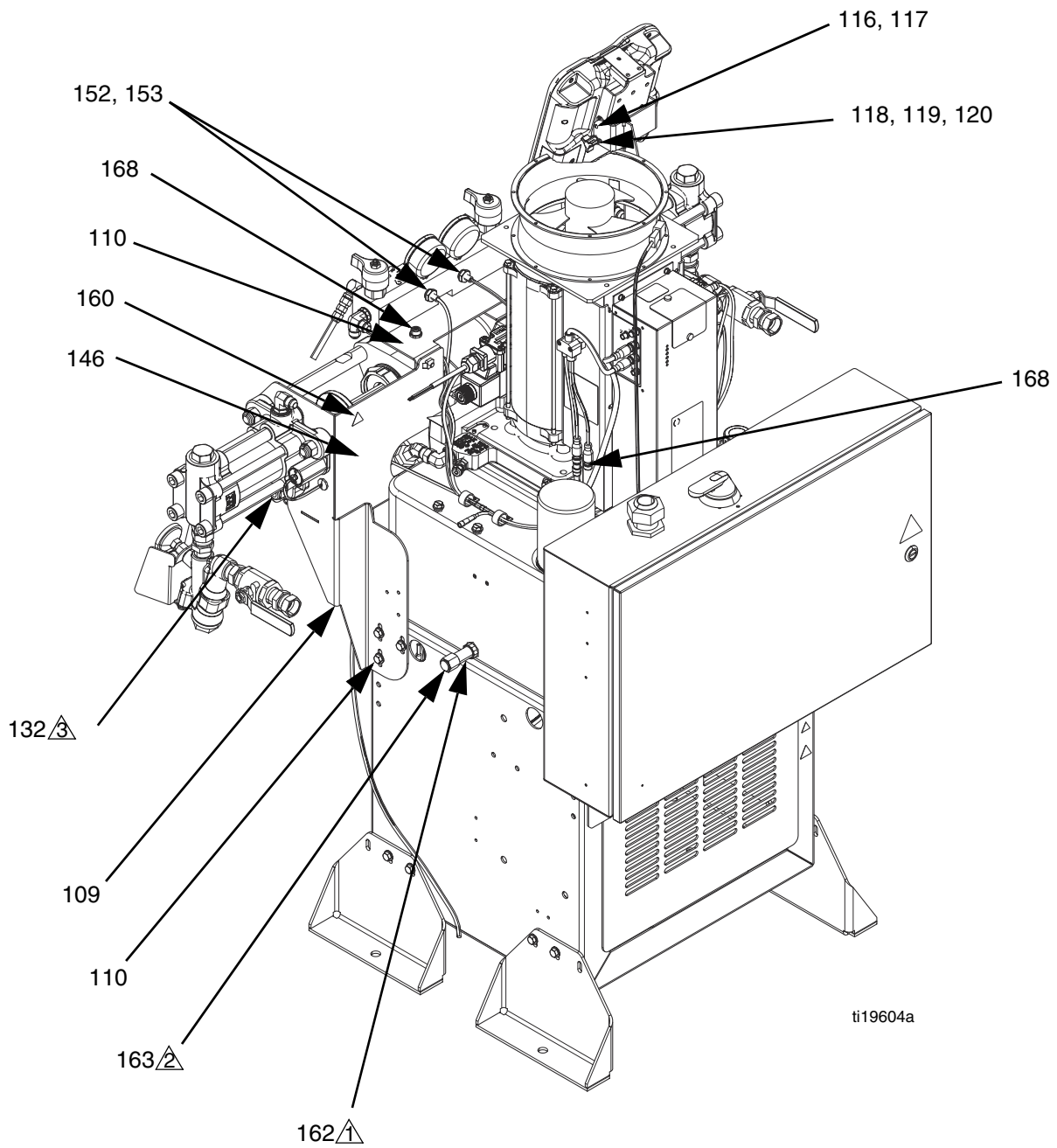

FIG. 12: Base Machine, Image 2 of 6



- △1 Torque to 40-50 ft-lb (54-68 N•m).
- △2 IsoGuard Select fluid, 24F516.
- △3 Torque to 17 ft-lb (23 N•m).

FIG. 13: Base Machine, Image 3 of 6



- 1 Apply sealant to pipe threads.
- 2 Do not apply sealant to threads.
- 3 Torque to 40-50 ft-lb (54-68 N•m).

FIG. 14: Base Machine, Image 4 of 6

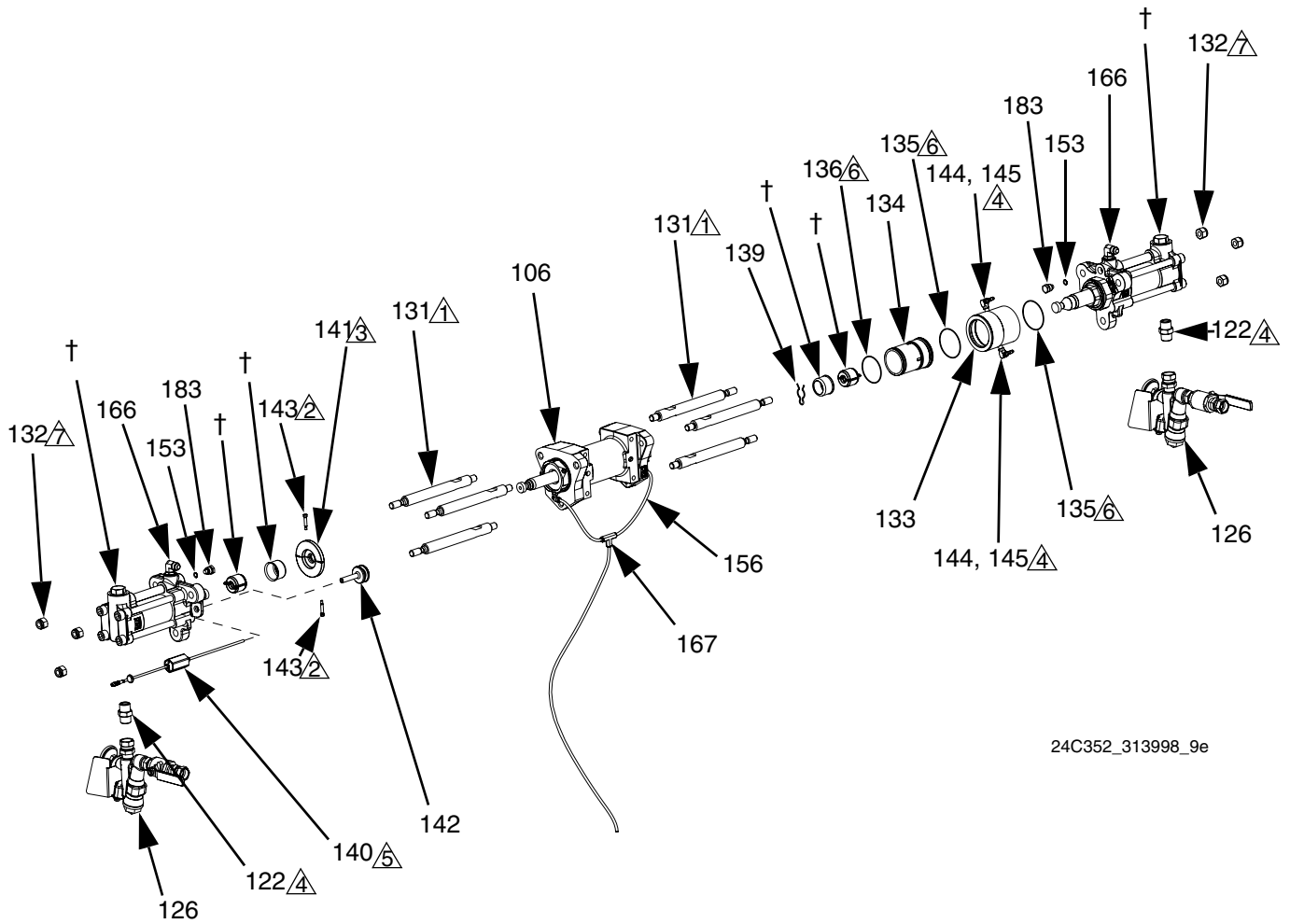

24C352\_313998\_9e

- 1 Torque to 50-60 ft-lb (68-81 N•m).
- 2 Torque to 40-50 ft-lb (54-68 N•m).
- 3 Assemble to orientation shown.
- 4 Apply sealant to pipe threads.
- 5 Apply a very thin coating of lubricant to the sensor tube.
- 6 Apply a thin coating of lubricant.
- 7 Snug only enough to hold pump module in place until final torque is applied later in assembly.

FIG. 15: Base Machine, Image 5 of 6

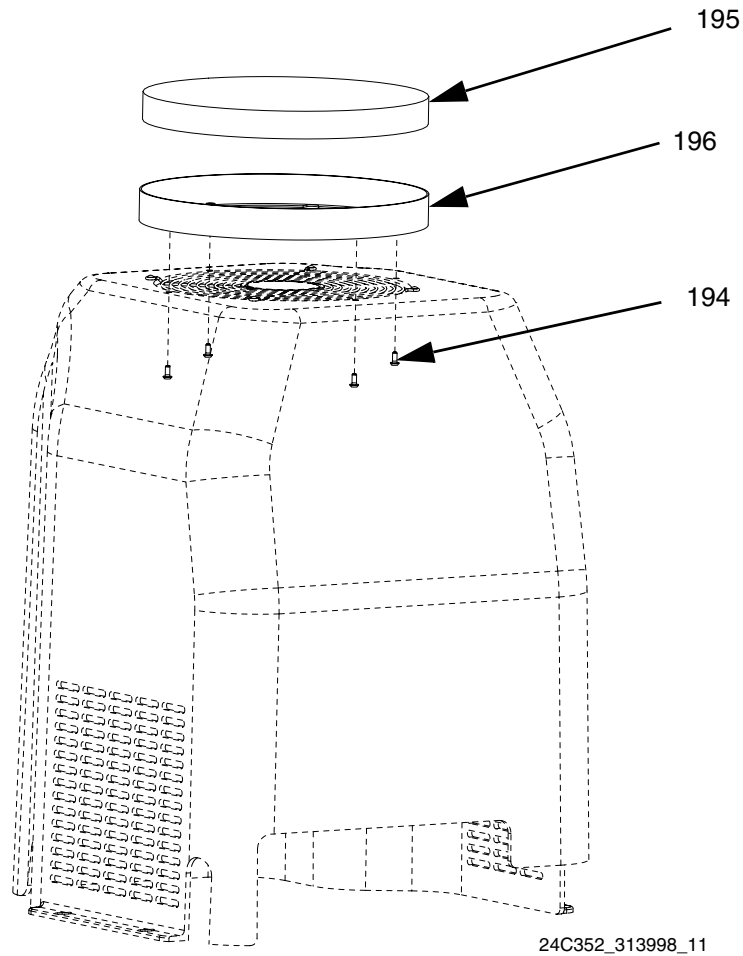

FIG. 16: Base Machine, Image 6 of 6



Ref	Part	Description	Quantity	
			BASE, fixed ratio, non-stainless	BASE, fixed ratio, stainless
101		MODULE, power pack, enclosure, assy	1	1
102	24M024	BRACKET, anchor	4	4
104	24E170	BRACKET, manifold	1	1
105	103413	PACKING, o-ring	2	2
106	258771	DRIVER, hydraulic, horizontal	1	1
107	16E281	STUD, threaded, 3/8-16 x 6.0 long	4	4
108		BRACKET, pump, left	1	1
109		BRACKET, pump, right	1	1
110	111800	SCREW, cap, hex head	23	23
111	255629	MANIFOLD, inlet, fluid, h-controller	1	
	289999	MANIFOLD, fluid, sst		1
112	113796	SCREW, flanged, hex hd	4	4
114	24E647	BRACKET, ADM mounting	1	1
115	255235	BRACKET, mounting, assembly	1	1
116	120060	CLIP, speed, tubular	2	2
117	122168	RIVET, aluminum	2	2
118	110755	WASHER, plain	1	1
119	100016	WASHER, lock	1	1
120	121253	KNOB, display adj.	1	1
121	24E451	MODULE, ADM, w/ USB	1	1
122	123111	FITTING, nipple, hex, 3/4 NPT, 3k, ss		2
	C20487	FITTING, nipple, hex	2	
123	24C234	COVER, shroud, front	1	1
124	117502	FITTING, reducer #5 x #8 (JIC)	1	
	16A361	FITTING, reducer, #5 x #8 (JIC), sst		1
125	117677	FITTING, reducer #6 x #10 (JIC)	1	
	16A362	FITTING, reducer, #6x #10 (JIC), sst		1
126	255159	KIT, assembly, pair, inlet	1	
		KIT, pair, inlet, sst, no filter		1
127	24B855	COVER, assembly	1	1
128	297216	BRACKET, reservoir, lube	1	1
129	295187	SCREW, machine, ph, 8 x 3/8	2	2
130	258707	RESERVOIR, bottle, assembly	1	1
131	15X519	ROD, tie, 12 lng, 5/8-11 unc	6	6
132	101712	NUT, lock	6	6
133	15Y596	HOUSING, iso lube, telescoping	1	1
134	15Y595	HOUSING, iso lube, telescoping	1	1
135	C20278	PACKING, o-ring	2	2
136	122892	O-RING, fluoroelastomer, 038	1	1
139	125966	CLIP, hairpin	1	1
140	258669	SENSOR, assembly	1	1
141	16A509	COLLAR, sensor, lvdt	1	1
142	258704	SPOOL, assembly, lvdt	1	1
143	119999	BOLT, shoulder	2	2
144	191892	FITTING, elbow, street, 90 deg	2	2
145	116746	FITTING, barbed, plated	2	2

Parts

Ref	Part	Description	Quantity	
			BASE, fixed ratio, non-stainless	BASE, fixed ratio, stainless
146	24C235	COVER, pump	1	1
147	24C153	COVER, heat exchanger	1	1
150	123313	VALVE, directional, hydraulic	1	1
151	123366	SCREW, shc, 10-24 x 1.125, s	4	4
152	16A093	SENSOR, pressure, fluid outlet	2	2
153	121399	PACKING, o-ring 012 fx75	4	4
154	121002	CABLE, can, female / female 1.5m	1	1
155	205447	COUPLING, hose	2	2
156	054826	TUBE, plastic	10	10
157	123798	CABLE, m8, 4-pin, mf, 1m, molded	1	1
158	120999	RESISTOR, terminal, turck rke 57-tr2	1	1
160	15H108▲	LABEL, pinch point	1	1
161		COVER, enclosure, slotted, asmbly	1	1
162	122970	FITTING, adapter, JIC (08) x sae (08), m	1	1
163	123140	FITTING, cap, 1/2 JIC , cs	1	1
164		SEALANT, pipe, sst	1	1
165		SEALANT, anaerobic	1	1
166	121312	FITTING, elbow, sae x JIC	2	
	123108	FITTING, elbow, 3/4 sae x 1/2 JIC, sst		2
167	123112	FITTING, t, 1/4 tube, prestolock, brass	1	1
168	121581	HARNESS, I/O, M12 x M12	1	1
170	054175	TUBE, nylon, rd	5	5
171		LUBRICANT, grease	1	1
173	24F516	FLUID, ISO-Guard Select, 6 qt.	1	1
174		LABEL, identification	1	1
175		LABEL, HFR metering system	1	1
176	15M511▲	LABEL, warning, eng/span/fre	1	1
177		FLUID, hydraulic (gallon)	9	9
178	117792	GUN, grease, 3 oz	1	1
179	117773	LUBRICANT, grease, food grade	1	1
180	555621	WASHER, 3/8 plain flat	4	4
181	15V551	SHIELD, membrane, ADM	0.100	0.100
187	16E277	BUSHING, flanged, 1.0 x 1.25 x 1.0	4	4
188	U90126	NUT, hex, 3/8-16, ms, gr8	4	4
189	071019	ADHESIVE, anaerobic	1	1
193	124804	SCREW, hex, slotted	4	4
194	15U075	SCREW, cap, bh, 8-32 x 0.37	4	4
195	24H018	FILTER, air	1	1
196	16G251	HOUSING, filter	1	1
199	16H821	TOKEN, software upgrade	1	1

† See Z-Series Chemical Pumps manual for parts information.

▲ Replacement Danger and Warning labels, tags and cards are available at no cost.

## **Base Machine Sub-Assemblies**

### **HFR Hydraulic Driver 258771**

See the HFR Hydraulic Driver manual 3A0020 for parts information.

### **Z-Series Chemical Pumps**

See the Z-Series Chemical Pumps manual for parts information.

### **Power Distribution Boxes**

See the Power Distribution Boxes manual for parts information.

**Non-Stainless Steel Fluid Manifold 255629,  
Stainless Steel Fluid Manifold 289999  
Aluminum Manifold with Stainless Steel Fittings, 24P166**

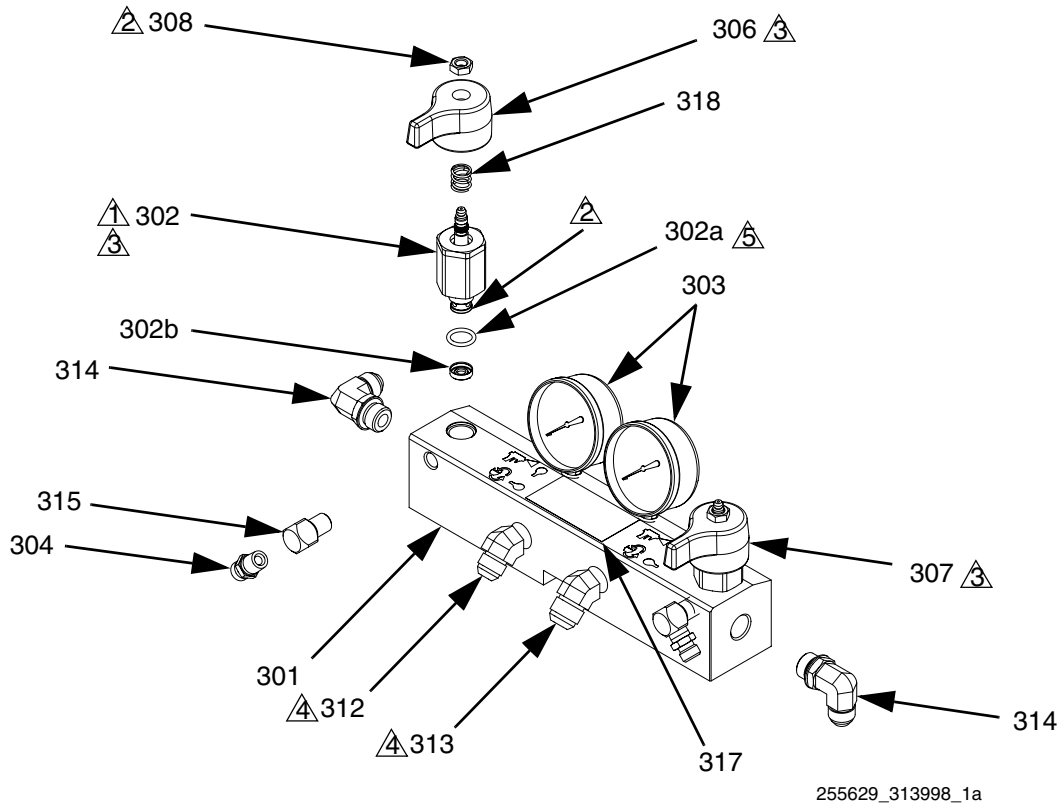

- 1 Torque to 355-395 in-lb (40.1-44.6 N•m)
- 2 Apply sealant (113500) to threads.
- 3 Valve must be closed with handle position as shown on drawing.
- 4 Adapter fittings for hoses are included in base machine parts. See **Base Machine** starting on page 39 for part numbers.
- 5 For assembly 24P166, replace o-ring that comes standard with item 302.

\*\*Apply PTFE or thread sealant to tapered threads.

Ref	Part			Description	Qty
	Assembly 255629	Assembly 289999	Assembly 24P166		
301	247837	24E307	255228	MANIFOLD, fluid	1
302†	247824	24E306	24E306**	VALVE, drain cartridge	2
.302a	158674†	158674†	556560**	O-RING	1
302b†	247779	247779	247779	SEAL, seat, valve	1
303	102814	112941	112941	GAUGE, pressure, fluid	2
304	162453	166846	166846	FITTING	2
306	247788	247788	247788	HANDLE, red	1
307	247789	247789	247789	HANDLE, blue	1
308†	112309	112309	112309	NUT, hex, jam	2
312	117556	123106	123106	NIPPLE, #8 JIC x 1/2 npt	1
313	117557	123107	123107	NIPPLE, #10 JIC x 1/2 npt	1
314	121312	123108	126565	ELBOW, 90 degrees	2
315	100840	166866	166866	ELBOW, street, 1/4 npsm x 1/4 npt	2
317▲	189285	189285	189285	LABEL, caution	1
318†	150829	150829	150829	SPRING, compression	2

▲ Replacement Warning labels, signs, tags, and cards are available at no cost.

† Included in the following complete valve kits\*:

**Assembly 255629**

A (Red) Valve Kit (left/red handle) 255149.

B (Blue) Valve Kit (right/blue handle) 255150.

Valve Set Kit (both handles and grease gun) 255148.

**Assembly 289999:**

A (Red) Valve Kit (left/red handle) 24E309.

B (Blue) Valve Kit (right/blue handle) 24E310.

Valve Set Kit (both handles and grease gun) 24E308.

\* Complete valve kits also include thread sealant. (Purchase kits separately).

\*\* When replacing item 302, item 302a must be ordered to replace the standard o-ring that comes with item 302.

**Non-SST Fluid Inlet Assemblies, 255159**  
**Aluminum Fluid Inlet Assemblies with Stainless Steel Fittings, 24P167**

**A Side Shown**

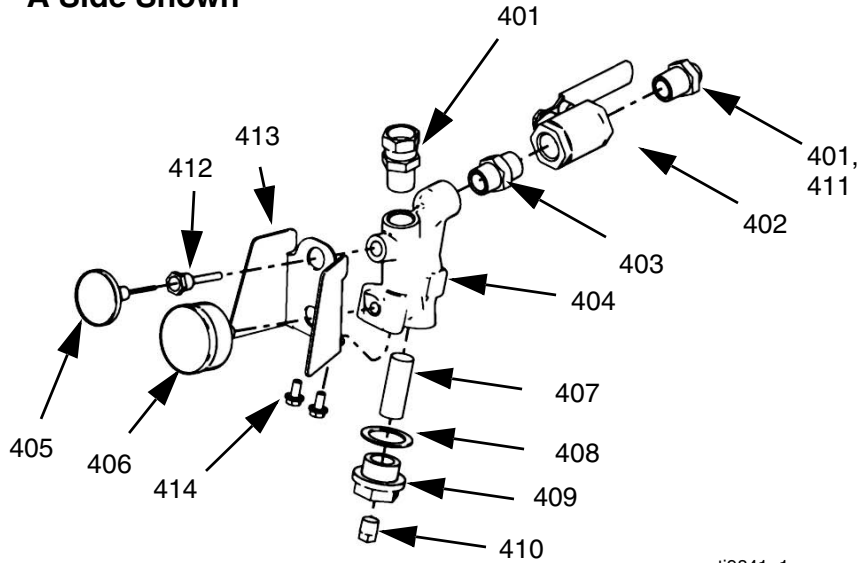

ti9841a1

\*\* Apply sealant to all non-swivel fittings.

Ref	Part		Description	Qty
	Assembly 255159	Assembly 24P167		
401	118459	112268	UNION, swivel; 3/4 npt(m) 3/4 npsm(f)	3
402	---	---	VALVE, ball; 3/4 npt (FBE)	2
403	---	---	NIPPLE; 3/4 npt	2
404	247503	247503	MANIFOLD, strainer, inlet	2
405	102124	102124	THERMOMETER, dial	2
406	120300	120300	GAUGE, pressure, fluid	2
407	180199	180199	ELEMENT, filter; 20 mesh (standard)	2
408	15H200	15H200	GASKET, strainer; PTFE	2
409	15H199	15H199	PLUG, strainer	2
410	---	---	PLUG, pipe; 3/8 npt	2
411	296178	123980	UNION, swivel; 3/4 npt(m) x 1/2 npt(f); A side only	1
412	15D757	15D757	HOUSING, thermometer	2
413	253481	253481	GUARD, gauge	2
414	111800	111800	SCREW, cap, hex hd, 5/16-18 x 5/8 in. (16 mm)	4
415	---	---	SEALANT, pipe, sst	1

--- Not available for individual sale.

## SST Fluid Inlet Assemblies

*B (Blue) Side Assembly shown,  
A (Red) Assembly also included*

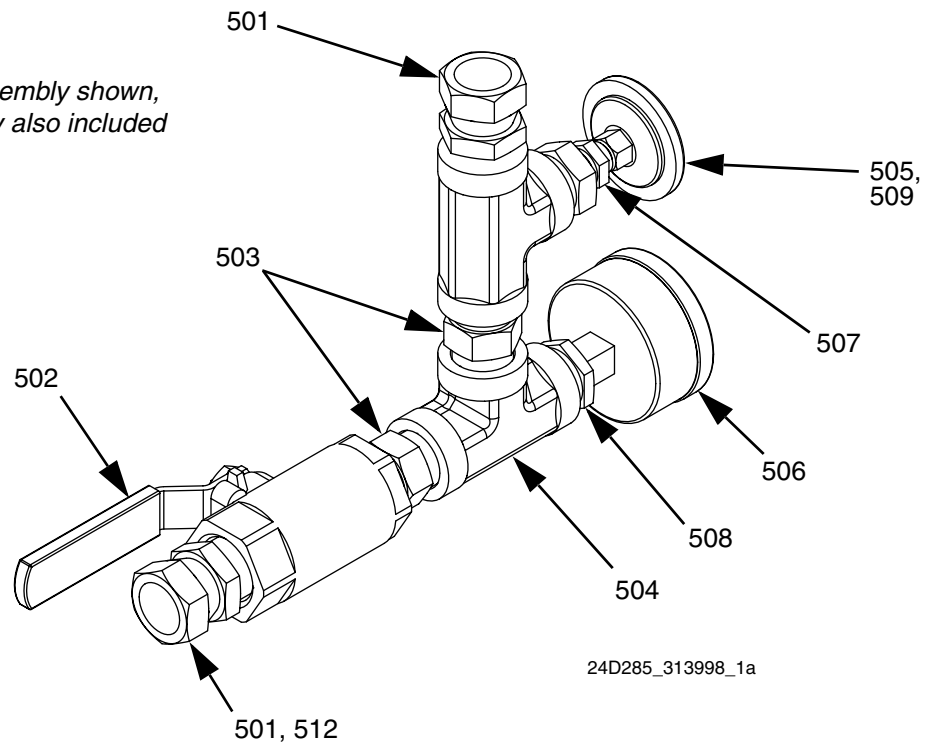



\*\* Apply sealant and tape to all non-swiveling threads.

Ref	Part	Description	Qty
501	112268	SWIVEL, union	3
502	512485	VALVE, ball, sst	2
503	123111	FITTING, nipple, hex, 3/4npt, 3k, ss	4
504	501118	FITTING, tee	4
505	102124	THERMOMETER, dial	2
506	120300	GAUGE, press, fluid, (waterborne)	2
507	500352	BUSHING, hex hd, sst	2
508	516308	FITTING, bushing, reducer, sst	2
509	15D757	HOUSING, thermometer, viscon <sup>®</sup> hp	2
510		SEALANT, pipe, sst	1
511		TAPE, tfe, sealant	1
512	123980	FITTING, straight, swivel, 1/2 x 3/4, FM, sst	1

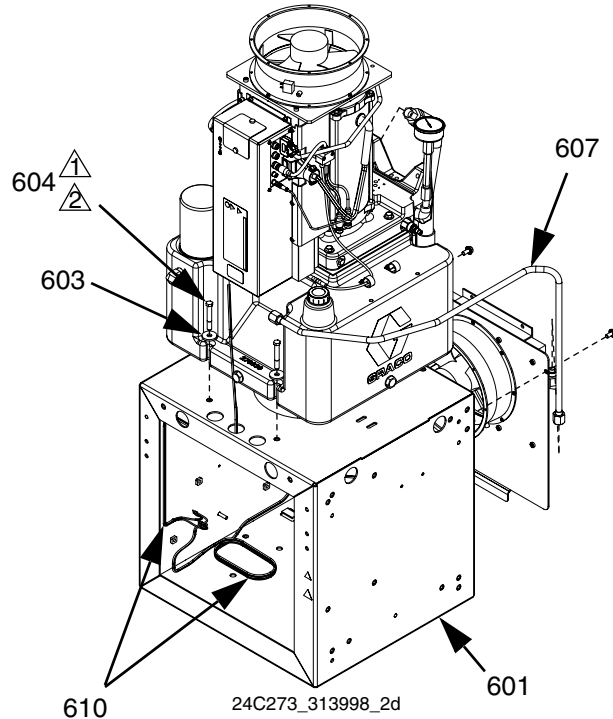
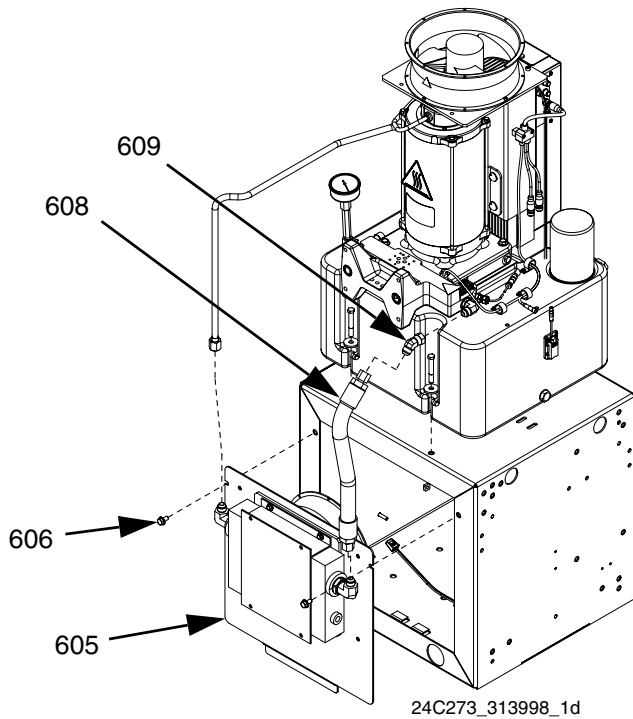
## Power Pack Module



-  Torque to 10 ft-lb (14 N•m).
-  Apply sealant to threads.

Ref	Part	Description	Qty
601		ENCLOSURE, frame, painted	1
602		MODULE, hydraulic power	1
603	U90205	WASHER, flat, 3/8, 0.41 x 1.25 x 0.13, ms	4
604	802277	SCREW, machine (matrix)	4
605		COVER, enclosure, heat exch, assy	1
606	111800	SCREW, cap, btn hd (matrix)	2
607	15Y935	TUBE, heat exchanger, outlet	1
608	24C621	HOSE, heat exchanger, inlet	1
609	123528	FITTING, elb, swvl, 45, jic08, fm, 6k	1
610	24C518	CORD, fan, heat exch, mcm	2
611		SEALANT, anaerobic	1
612	189930▲	LABEL, caution, electric shock (not shown)	1
613	15H108▲	LABEL, pinch point (not shown)	1

▲ Replacement Danger and Warning labels, tags and cards are available at no cost.





# Power Pack Module Sub-Assemblies

## Hydraulic DC Power Pack Module

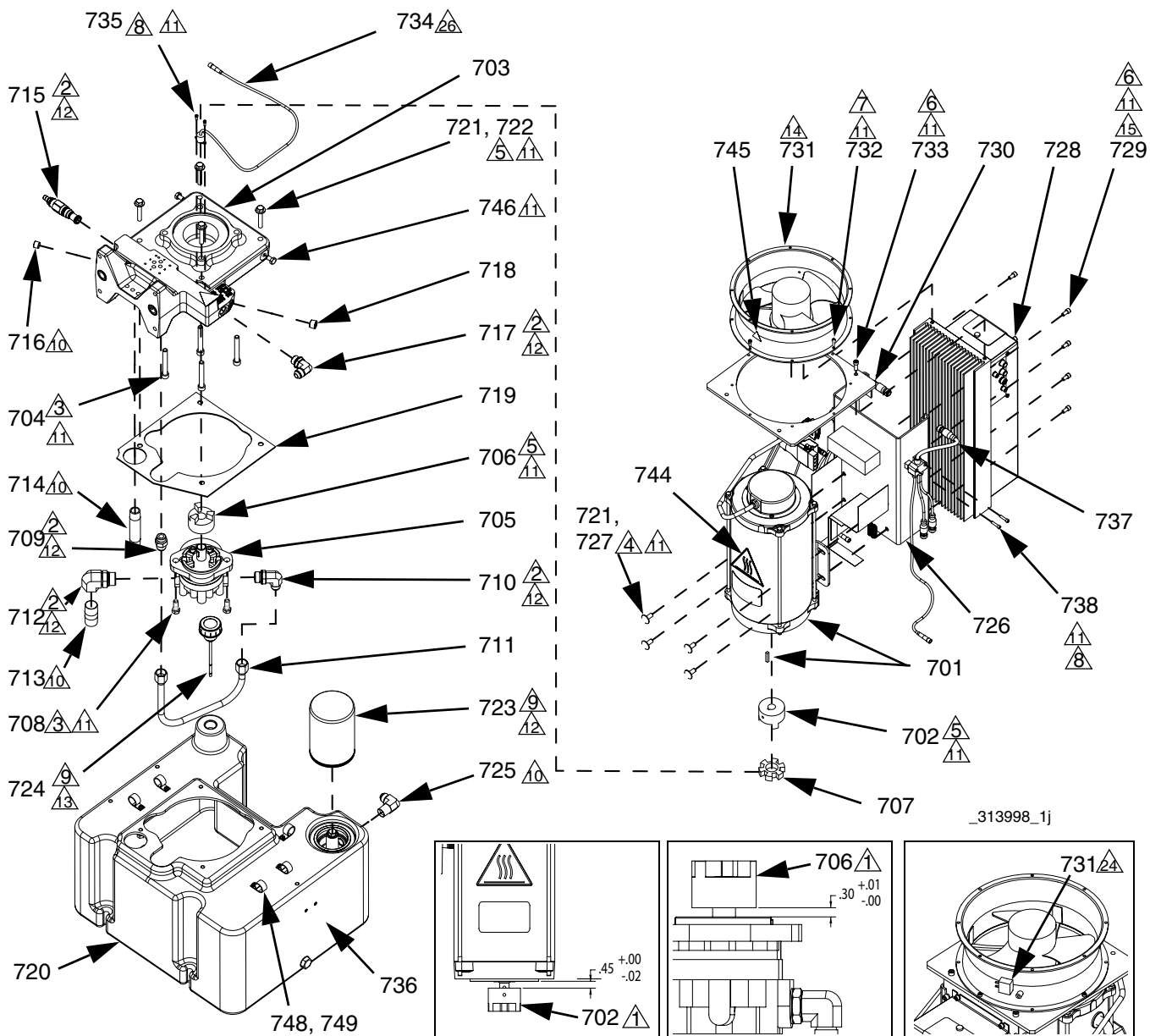

- Assemble coupler to specified dimensions prior to mounting assembly to housing.
- Torque to 40 ft-lb (54 N•m).
- Torque to 35 ft-lb (47 N•m).
- Torque to 20 ft-lb (27 N•m).
- Torque to 15 ft-lb (20 N•m).
- Torque to 10 ft-lb (14 N•m).
- Torque to 58 in-lb (6.5 N•m).

- Torque to 34 in-lb (3.8 N•m).
- Torque 1/4 turn past hand-tight.
- Apply PTFE tape on installation end only.
- Apply medium strength threadlocker prior to assembly.
- Apply light coating of lubricant to seals.
- Fill reservoir with hydraulic fluid.

- Orient with airflow arrow pointing toward mounting bracket.
- Prior to installing Ref. 728 into Ref. 726, install Ref. 729 into Ref. 728 and adjust head 1/8 in. from surface.
- Align fan plug as shown.
- Apply thermal lubricant to contact side.

FIG. 17: Hydraulic DC Power Pack

Ref	Part	Description	Qty
701	24C719	MOTOR, power connector, assembly	1
702	16A951	COUPLER, motor	1
703	15W772	HOUSING, machined.hydraulic, module	1
704	123338	SCREW, shc, 3/8-16 x 2.75, s(matrix)	4
705	122295	PUMP, gear, hydraulic, h39	1
706	16A952	COUPLER, pump	1
707	16A953	COUPLER, spider	1
708	123942	SCREW, cap, hex hd (matrix)	2
709	15T939	FITTING, straight, jic8 x sae8	1
710	122520	FITTING, elbow, male, sae x jic	1
711	15W798	TUBE, pump to tube outlet	1
712	122606	FITTING, elbow, male, female	1
713	100627	NIPPLE, short	1
714	101353	FITTING, nipple, pipe	1
715	122527	VALVE, relief, t-10a cavity, 0-25g	1
716	100721	PLUG, pipe	1
717	121312	FITTING, elbow, sae x jic	1
718	101754	PLUG, pipe	1
719	15X622	GASKET, housing, to, tank	1
720		RESERVOIR, assembly, 8 gallon	1
721	101971	WASHER, thrust	4
722	111302	SCREW, cap, hex hd (matrix)	4
723	15J937	FILTER, oil, 18-23 psi bypass	1
724	116915	CAP, breather filler	1
725	121486	FITTING, elbow, male, 1/2jic x 1/2npt	1
726	15Y912	BRACKET, mcm mounting	1
727	100057	SCREW, cap hex hd (matrix)	4
728	257396	MODULE, motor control	1
729	101550	SCREW, cap, sch (matrix)	7
730		PLATE, mounting, fan	1
731	122301	FAN, 220v	1
732	112310	SCREW, cap, sch (matrix)	8
733	100644	SCREW, cap, sch (matrix)	2
734	123367	HARNESS, m8 x thermal switch, 4-pin	1
735	102410	SCREW, cap soc hd (matrix)	1
736		FLUID, hydraulic (gallon)	8
737	123303	HARNESS, m12	2
738	295709	SCREW, soc.hd (matrix)	4
739		LUBRICANT, grease	1
740		SEALANT, pipe, sst	1
741		SEALANT, pipe, sst	1
743	189285▲	LABEL, caution	1
744	121208▲	LABEL, hot surface	1
745	15H108▲	LABEL, pinch point	1
746	109468	SCREW, cap, hex head	2
747		LUBRICANT, thermal	1
748	123601	CLAMP, wire, harness, nylon, 3/4	5
749	103833	SCREW, mach, crbh	5

▲ Replacement Danger and Warning labels, tags and cards are available at no cost.

## Heat Exchanger Assembly

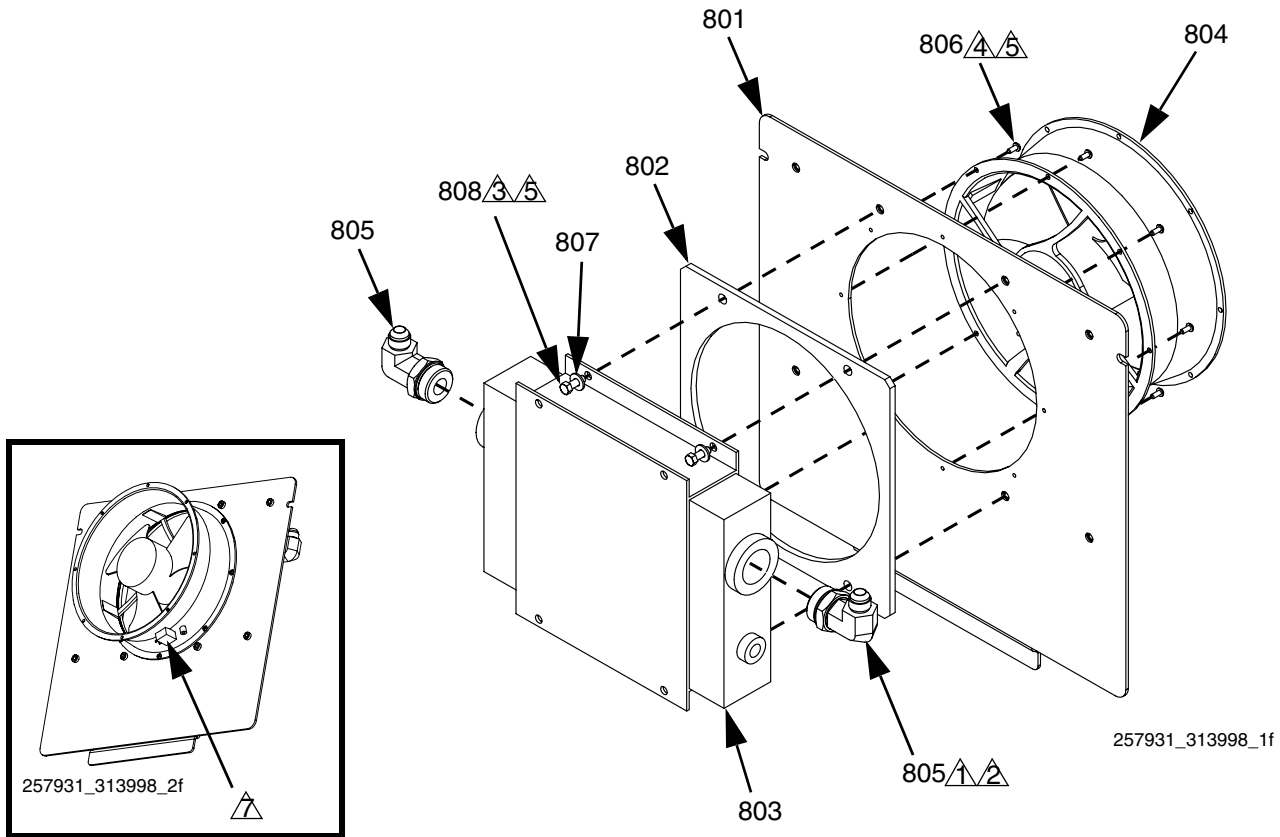

- ① Torque to 65 ft-lb (88 N•m).
- ② Apply lubricant to o-rings before assembling.
- ③ Torque to 8 ft-lb (11 N•m).
- ④ Torque to 2.5 ft-lb (3.4 N•m).
- ⑤ Apply sealant to threads.
- ⑥ Orient fan with airflow arrow pointing toward cover.
- ⑦ Align fan plug as shown.

Ref	Part	Description	Qty
801	257967	COVER, enclosure, heat exch, painted	1
802	15X621	GASKET, fan, mounting	1
803	122300	EXCHANGER, heat, m-4	1
804	122301	FAN, 220v	1
805	122842	FITTING, elbow, sae x jic	2
806	15U075	SCREW, cap, bh, 8-32 x .37(matrix)	8
807	110755	WASHER, plain	4
808	100022	SCREW, cap, hex hd (matrix)	4
810		LUBRICANT, thread	1
811		SEALANT, anaerobic	1

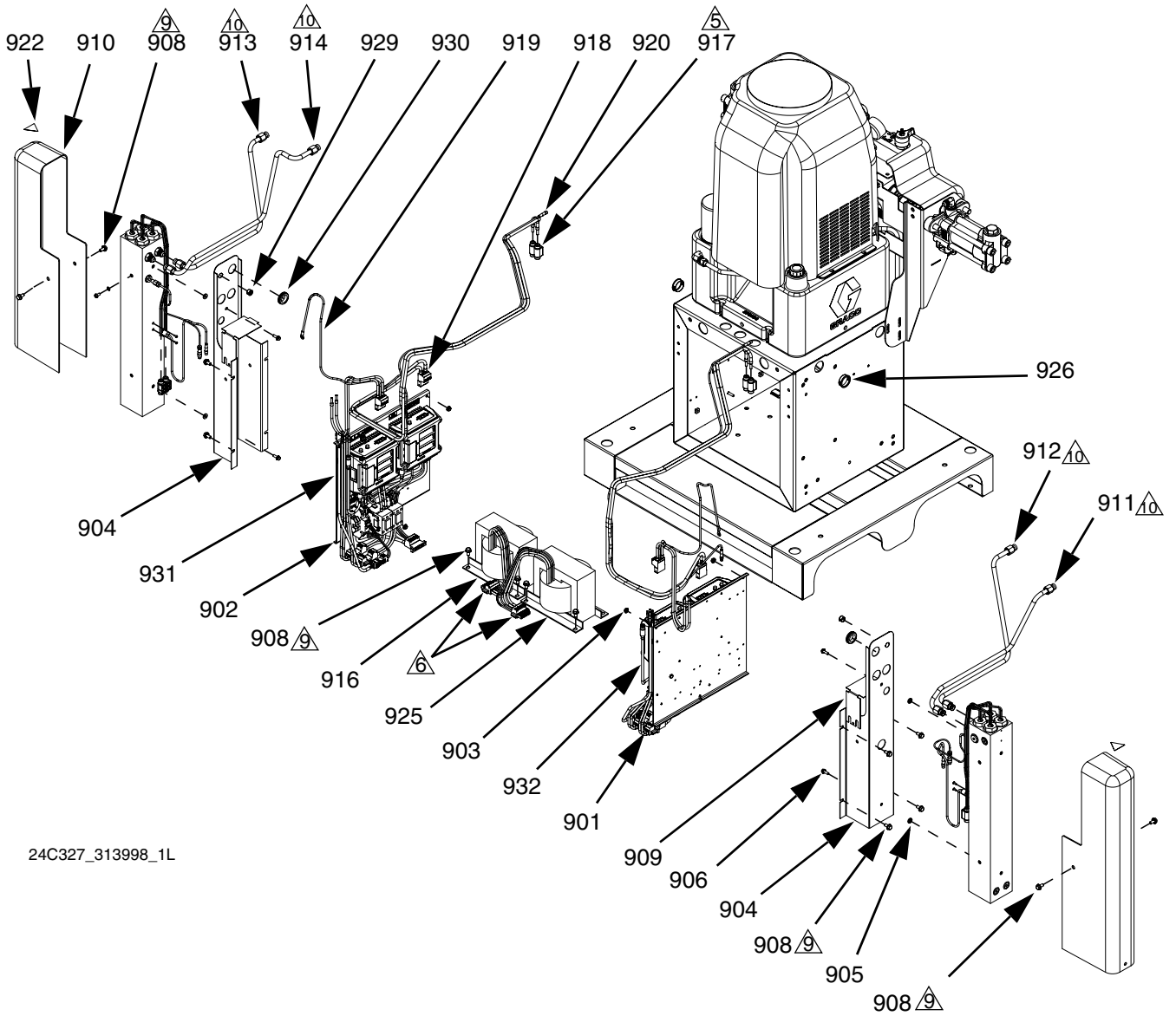

# Heater Options





24C327\_313998\_1L

-  Assembly NPT portion of Ref. 938 into Ref. 907. Tighten to tight minus 1 turn approximately. Insert Ref. 933 into Ref. 938 an tighten while holding against heater element. Tighten ferrule to 21-25 ft-lb (28-34 N•m). Hold NPT portion to prevent tightening.



 Tighten NPT thread at least one turn after RTD has been tightened.

 Apply thermal lubricant when assembling Ref. 934.
-  Apply oxide inhibitor to bare ends of wires and to ferrule ends.

 Apply oxide inhibitor included in Ref. 917 to bare ends of wires and to ferrule ends.

 Torque to 16 in-lb (1.8 N•m).

 Connect to Ref. 920 through extension cable.

 Choose adapter and swivel fitting from kit based on hose size.
-  Torque to 17 ft-lb (23 N•m).

 Apply lubricant to threads of tube fitting and torque to 21 ft-lb (28 N•m).

 Apply sealant and tape to all non-swiveling and non-o-ring threads.

**FIG. 18: Heater Options, Image 1 of 4**

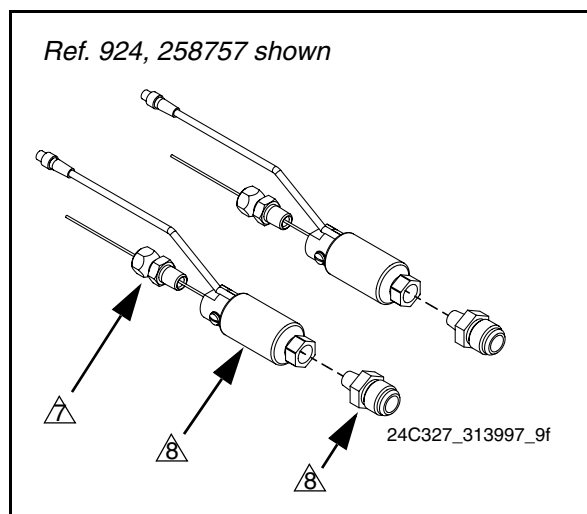
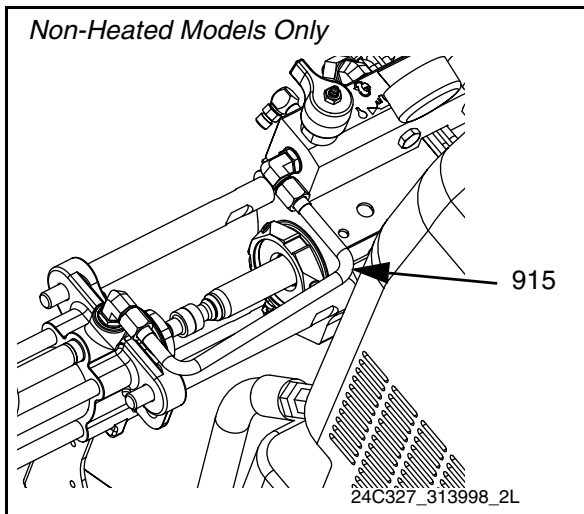
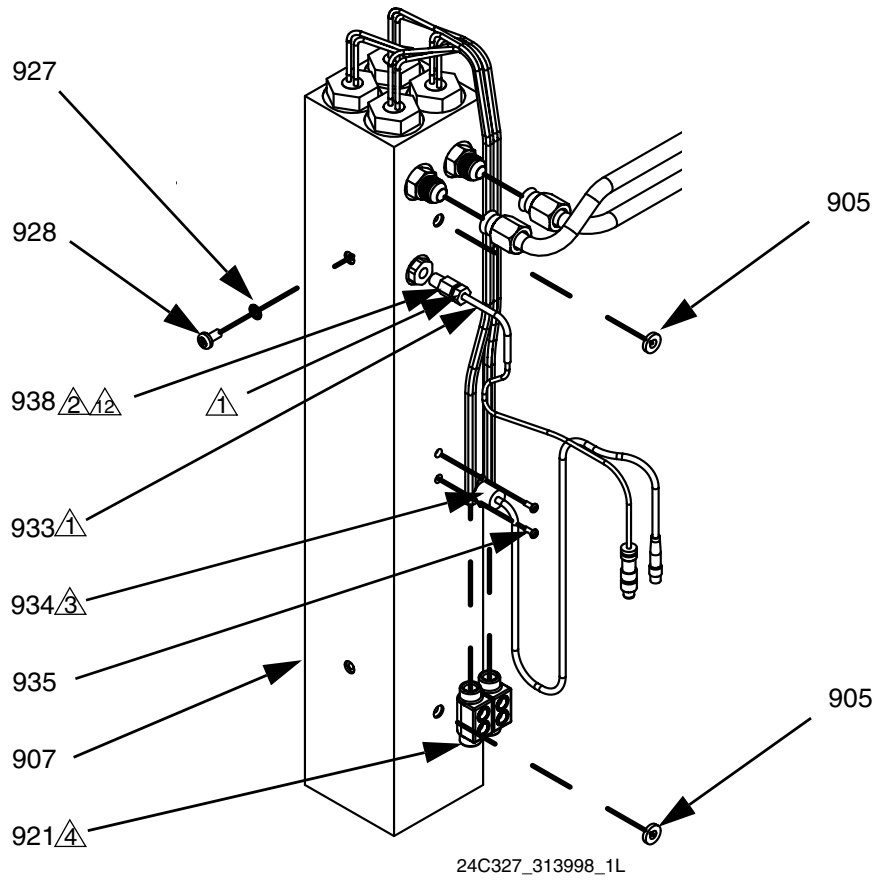

FIG. 19: Heater Options, Image 2 of 4

Ref	Part	Description	Quantity						
			A (Red) and B (Blue) Primary Heaters, A (Red) and B (Blue) Hose Heat	A (Red) and B (Blue) Primary Heaters, One Zone of Hose Heat	A (Red) and B (Blue) Hose Heat, Stainless Steel	A (Red) and B (Blue) Hose Heat, Carbon Steel	A (Red) and B (Blue) Primary Heaters	B (Blue) Primary Heaters, B (Blue) Hose Heat	No Heat
901		MODULE, panel, pwr, heat, hose, pr, lv	1	1					
		MODULE, panel, pwr, heat, hose, lv			1	1			
		MODULE, panel, pwr, heat, pri, lv					1		
902		MODULE, panel, pwr, heat, hose, pr, hv	1					1	
		MODULE, panel, pwr, heat, hose, hv			1	1			
		MODULE, panel, pwr, heat, pri, hv		1			1		
		MODULE, panel, pwr, no heat, hv							1
903	115942	NUT, hex, flange head	6	6	6	6	6	3	3
904	253192	BRACKET, painted, heater mount, poly	2	2			2	1	
905	167002	INSULATOR, heat	4	4			4	2	
906	113796	SCREW, flanged, hex hd (matrix)	4	4			4	2	
907	24C426	HEATER, assy, 6kw, 1-zone, rtd, s	2	2			2	1	
908	111800	SCREW, cap, hex hd (matrix)	16	14	4	4	12	8	
909	255360	COVER, wire, heater, painted	2	2			2	1	
910	253196	COVER, painted, heater, poly, h-25	2	2			2	1	
911	16A104	TUBE, fluid, a, inlet, heater, ams	1	1			1		
912	16A105	TUBE, fluid, a, outlet, heater, ams	1	1			1		
913	16A106	TUBE, fluid, b, inlet, heater, ams	1	1			1	1	
914	16A107	TUBE, fluid, b, outlet, heater, ams	1	1			1	1	
915	16A108	TUBE, fluid, no heater, ams			2	2		1	2
916	24C418	MODULE, transformer, assy, hv	1	1	1	1		1	
917	261821	CONNECTOR, wire, 6awg	2	1	2	2		1	
918	24C314	HARNESS, wire, hptcm, hoseheat, fixed	2	1	2	2		1	
919	24C312	HARNESS, wire, hptcm, heater, fixed	2	2			2	1	
920	122242	CABLE, m8, 4-pin, mf, 2.5m, mold	2	1	2	2		1	
921	255716	KIT, heater wire connector	1	1			1	1	
922	189285▲	LABEL, caution	2	2			2	1	
923		FLUID, oxide inhibitor	1	1			1	1	
924	258756	KIT, fts, rtd, dual hose, sst			1				
	258757	KIT, fts, rtd, dual hose	1			1			
	258758	KIT, fts, rtd, single hose		1				1	
925	24C779	MODULE, transformer, assy, lv	1		1	1			

Ref	Part	Description	Quantity						
			A (Red) and B (Blue) Primary Heaters, A (Red) and B (Blue) Hose Heat	A (Red) and B (Blue) Primary Heaters, One Zone of Hose Heat	A (Red) and B (Blue) Hose Heat, Stainless Steel	A (Red) and B (Blue) Hose Heat, Carbon Steel	A (Red) and B (Blue) Primary Heaters	B (Blue) Primary Heaters, B (Blue) Hose Heat	No Heat
926	123398	PLUG, hole, 1.5" dia			2	2			2
	123589	BUSHING, wire protector, snap-in	2	2			2	2	
927	100028	WASHER, lock	2	2			2	1	
928	113783	SCREW, machine, pn hd (matrix)	2	2			2	1	
929	103361	BUSHING, snap	2	2			2	1	
930	114269	GROMMET, rubber	2	2			2	1	
931	121002	CABLE, can, female / female 1.5m	1	1	1	1	1	1	
932	122487	CABLE, can, male-female, 1.5m	1	1	1	1	1		
933	124262	SENSOR, rtd, 1 k ohm, 5 ft, 4 pin, tip sensor	2	2			2	1	
934	123408	HARNESS, m8 x thermal switch, 3-pin	2	2			2	1	
935	100518	SCREW, mach, pnhd (matrix)	4	4			4	2	
936		LUBRICANT, thermal	1	1			1	1	
937		LUBRICANT, thread	1	1	1	1	1	1	1
938	123325	FITTING, compression, 1/8npt, ss	2	2			2	1	
939		SEALANT, pipe, sst	1	1			1	1	
940		TAPE, tfe, sealant	1	1			1	1	

▲ Replacement Danger and Warning labels, tags and cards are available at no cost.



24J707 Shown

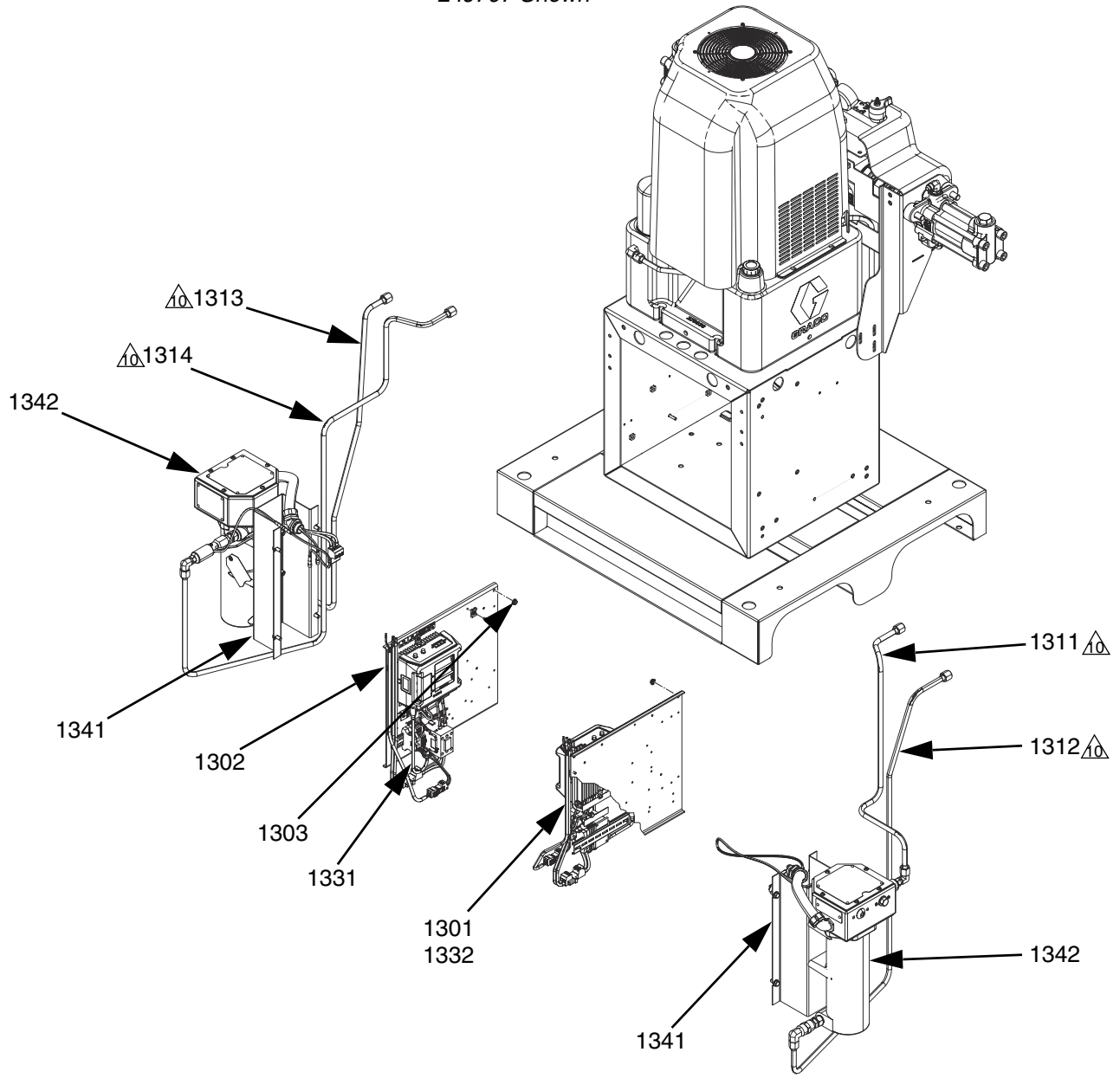

ti17873a

⚠ Torque to 17 ft-lb (23 N•m).

⚠ Apply lubricant to threads of tube fitting and torque to 21 ft-lb (28 N•m).

FIG. 20: Heater Options, Image 3 of 4

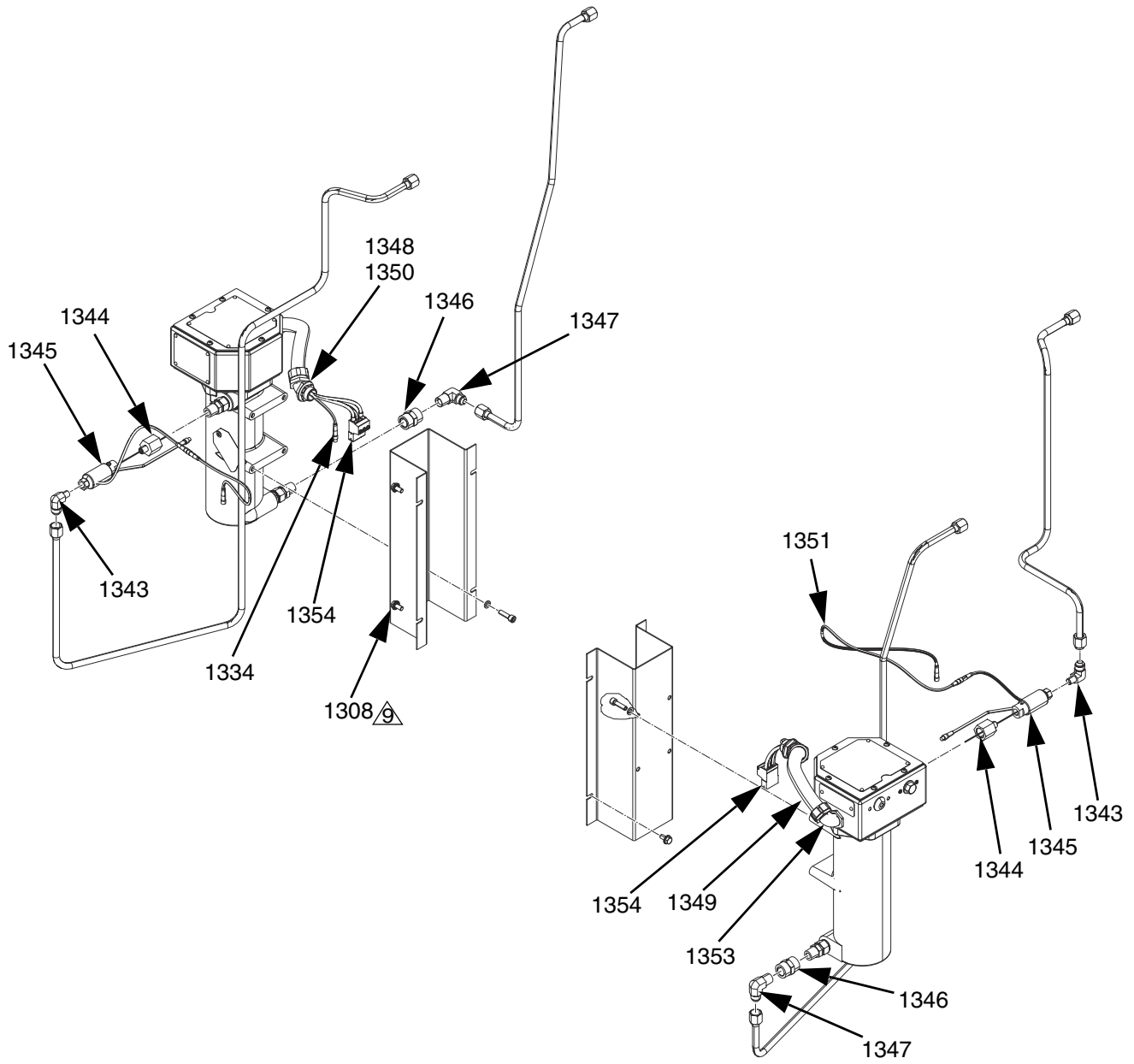

ti17874a

FIG. 21: Heater Options, Image 4 of 4

Ref	Part	Description	Quantity					
			24G617, HEATER, fix, pr, 1 hose, 1fts, viscon	24J105, HEATER, fix, pr, 1 viscon, 1 std	24J106, HEATER, fix, pr, 1 vis, 1 std, 2 hose	24J107, HEATER, fix, pr, 2viscon	24J108, HEATER, fix, pr, 2 viscon, 1 hose	24J109, HEATER, fix, pr, 2 viscon, 2 hose
1301	24C336	MODULE, panel, pwr, heat, hose, pr, lv	1		1		1	1
	24C338	MODULE, panel, pwr, heat, pri, lv		1		1		
1302	24C332	MODULE, panel, pwr, heat, hose, pr, hv			1			1
	24C334	MODULE, panel, pwr, heat, pri, hv	1	1		1	1	
1303	115942	NUT, hex, flange head	6	6	6	6	6	6
1304	253192	BRACKET, painted, heater mount, poly	1	1	1			
1305	167002	INSULATOR, heat	2	2	2			
1306	113796	SCREW, flanged, hex hd	2	2	2			
1307	24C426	HEATER, assy, 6kw, 1-zone, rtd, s	1	1	1			
1308	111800	SCREW, cap, hex hd	10	10	14	8	10	12
1309	255360	COVER, wire, heater, painted	1	1	1			
1310	253196	COVER, painted, heater, poly, h-25	1	1	1			
1311	16A104	TUBE, fluid, a, inlet, heater, ams	1	1	1			
	16H486	TUBE, fluid, outlet				1	1	1
1312	16A105	TUBE, fluid, a, outlet, heater, ams	1	1	1			
	16H485	TUBE, fluid, inlet				1	1	1
1313	16G338	TUBE, fluid, b, inlet, heater, visc	1	1	1	1	1	1
1314	16G339	TUBE, fluid, b, outlet, heater, vis	1	1	1	1	1	1
1316	24C418	MODULE, transformer, assy, hv	1		1		1	1
1317	261821	CONNECTOR, wire, 6awg	1		2		1	2
1318	24C314	HARNESS, wire, hptcm, hoseheat, fixed	1		2		1	2
1319	24C312	HARNESS, wire, hptcm, heater, fixed	1	1	1			
1320	122242	CABLE, m8, 4-pin, mf, 2.5m, mold	1		2		1	2
1321	255716	KIT, heater wire connector	1	1	1			
1322	189285	LABEL, caution	1	1	1			
1323	261843	FLUID, oxide inhibitor	1	1	1	1	1	1
1324	258756	KIT, fts, rtd, dual hose, sst			1			1
	258758	KIT, fts, rtd, single hose					1	
	24G976	KIT, fts, rtd, single hose, 1/2-2	1					
1325	24C779	MODULE, transformer, assy, lv			1			1
1327	100028	WASHER, lock	1	1	1			
1328	113783	SCREW, machine, pn hd)	1	1	1			
1329	103361	BUSHING, snap	1	1	1			
1330	114269	GROMMET, rubber	1	1	1			
1331	121002	CABLE, can, female / female 1.5m	1	1	1	1	1	1
1332	122487	CABLE, can, male-female, 1.5m	1	1	1	1	1	1
1334	123408	HARNESS, m8 x thermal switch, 3-pin	2	2	2	2	2	2
1335	100518	SCREW, mach, pnhd	2	2	2			
1336	073019	LUBRICANT, thermal	1	1	1	1	1	1

Ref	Part	Description	Quantity					
			24G617, HEATER, fix, pr, 1 hose, 1fts, viscon	24J105, HEATER, fix, pr, 1 viscon, 1 std	24J106, HEATER, fix, pr, 1 vis, 1 std, 2 hose	24J107, HEATER, fix, pr, 2viscon	24J108, HEATER, fix, pr, 2 viscon, 1 hose	24J109, HEATER, fix, pr, 2 viscon, 2 hose
1337	070268	LUBRICANT, thread	1	1	1	1	1	1
1338	123325	FITTING, compression, 1/8npt, ss	1	1	1			
1339	070408	SEALANT, pipe, sst	1	1	1	1	1	1
1340	070274	TAPE, tfe, sealant	1	1	1	1	1	1
1341	24J537	BRACKET, heater, viscon, hfr, painted	1	1	1	2	2	2
1342	24J787	HEATER, sst	1	1	1	2	2	2
1343	124813	FITTING, elbw, 90, jic08x1/4npt	1	1	1	2	2	2
1344	124814	FITTING, rducr, 1/2nptx1/4npt	1	1	1	2	2	2
1345	262120	SENSOR, fluid temp rtd	1	1	1	2	2	2
1346	124586	COUPLING, hex, 1/2npt	1	1	1	2	2	2
1347	124885	FITTING, elbow, 90, jic(08)x1/2npt	1	1	1	2	2	2
1348	124956	FITTING, elbow, 45 deg, 3/4 conduit	1	1	1	2	2	2
1349	124955	CONDUIT, 3/4, gray seal tite	1	1	1	2	2	2
1350	124909	WASHER, reducer, 1in-3/4in	2	2	2	4	4	4
1351	123798	CABLE, m8, 4-pin, mf, 1m, molded	1	1	1	2	2	2
1353	124957	FITTING, elbow, 90 deg, conduit	1	1	1	2	2	2
1354	24J142	HARNESS, wire, hptcm, heater, fixed	1	1	1	2	2	2
1355	114225	TRIM, edge protection	0.330	0.670	0.670			
1356	105676	SCREW, mach, pnh	1	1	1	2	2	2

# Heater Sub-Assemblies

## Heat Power Panel Module

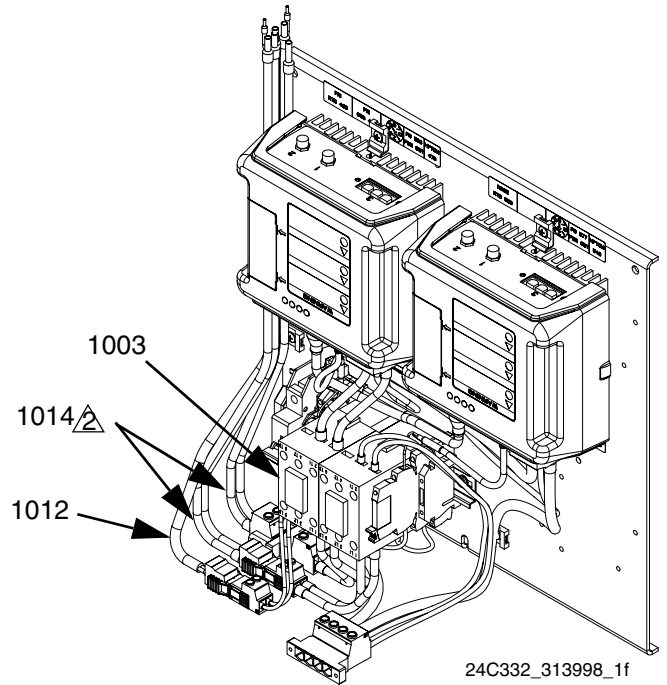
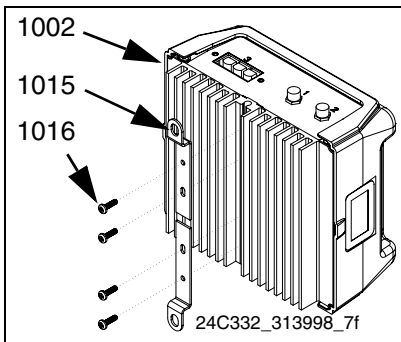
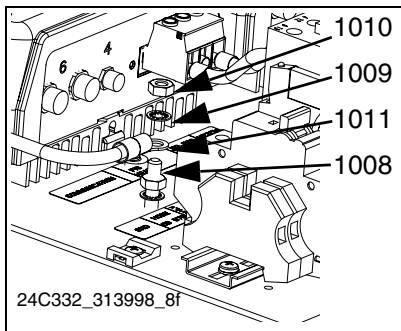
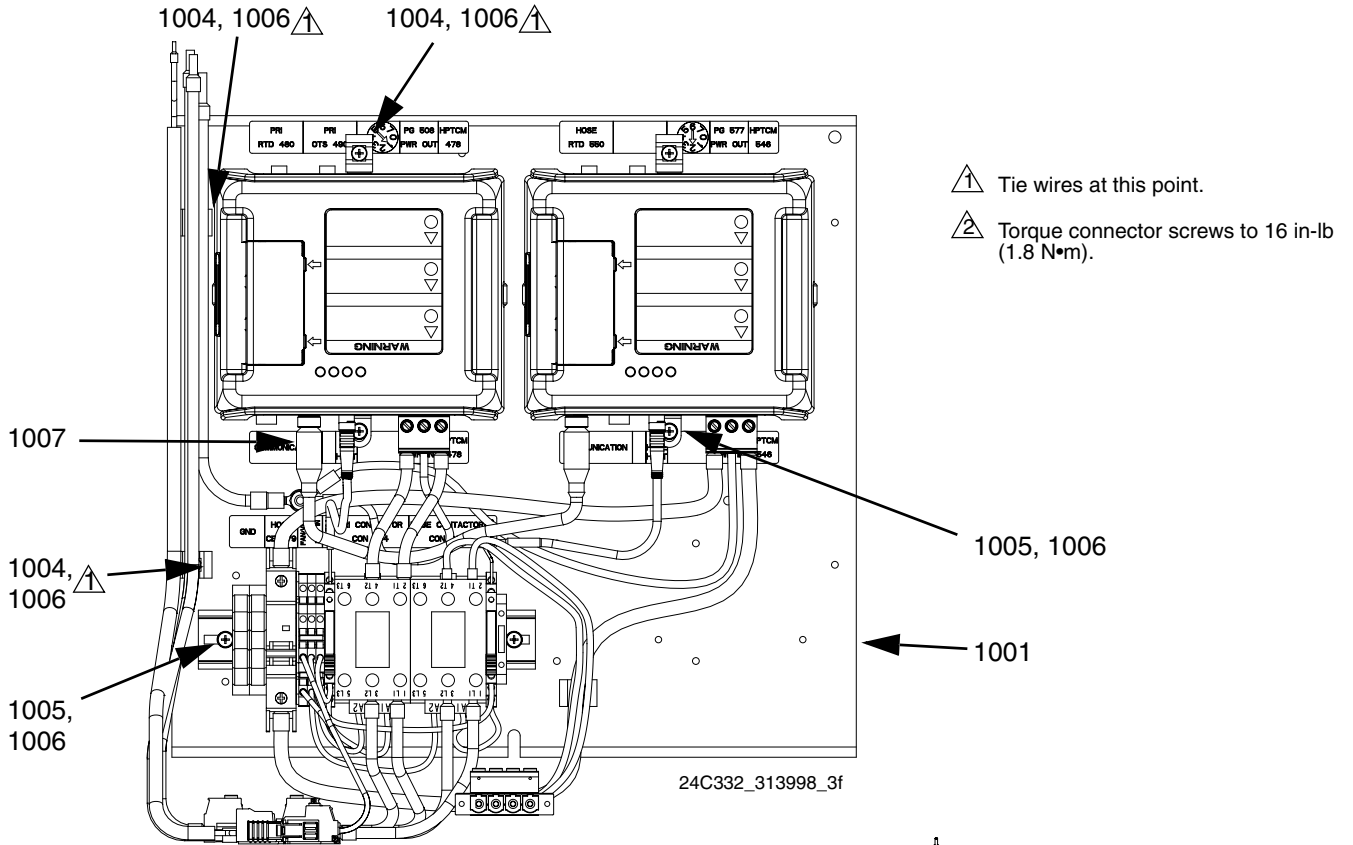

FIG. 22: Heat Power Panel Modules

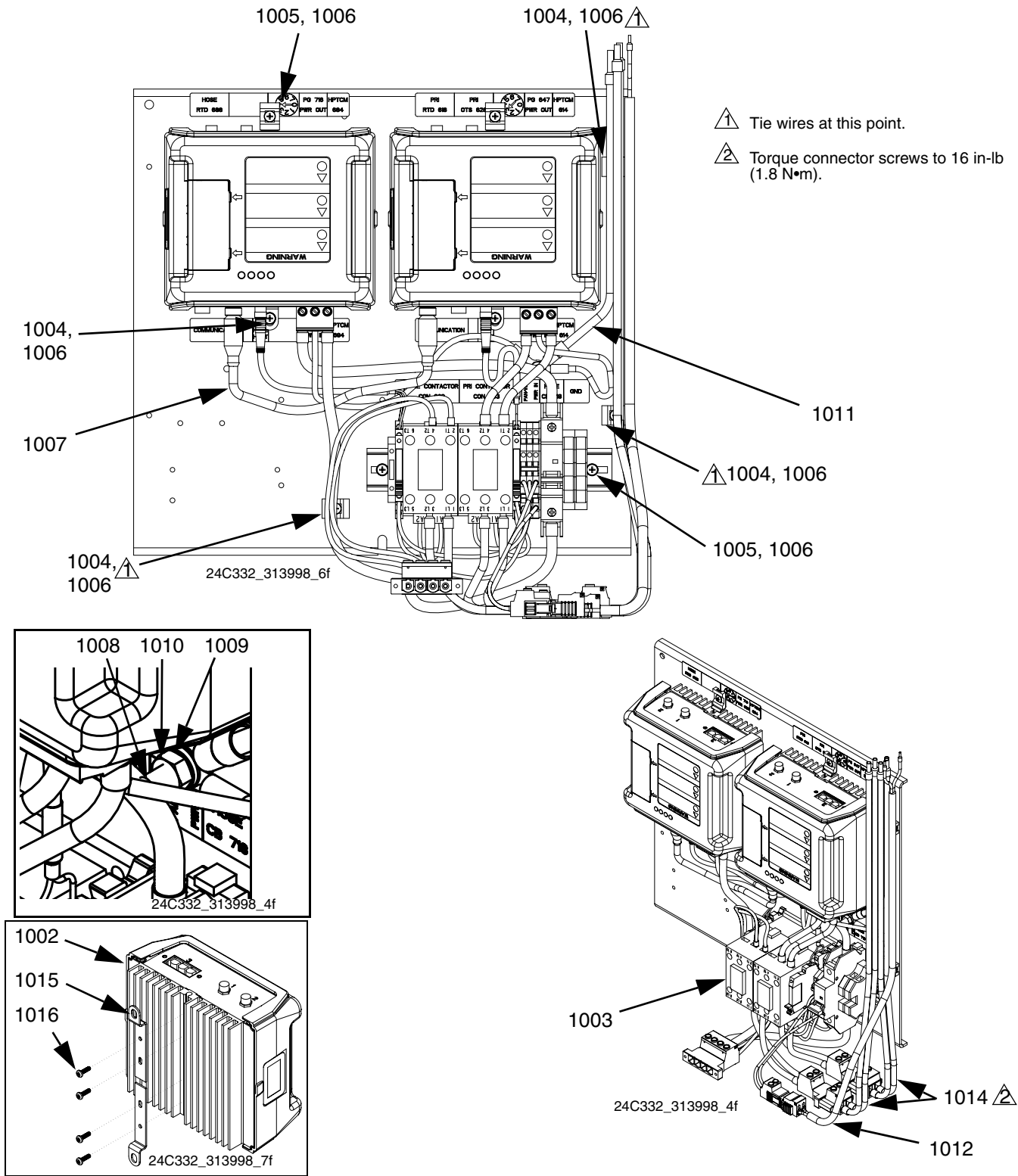
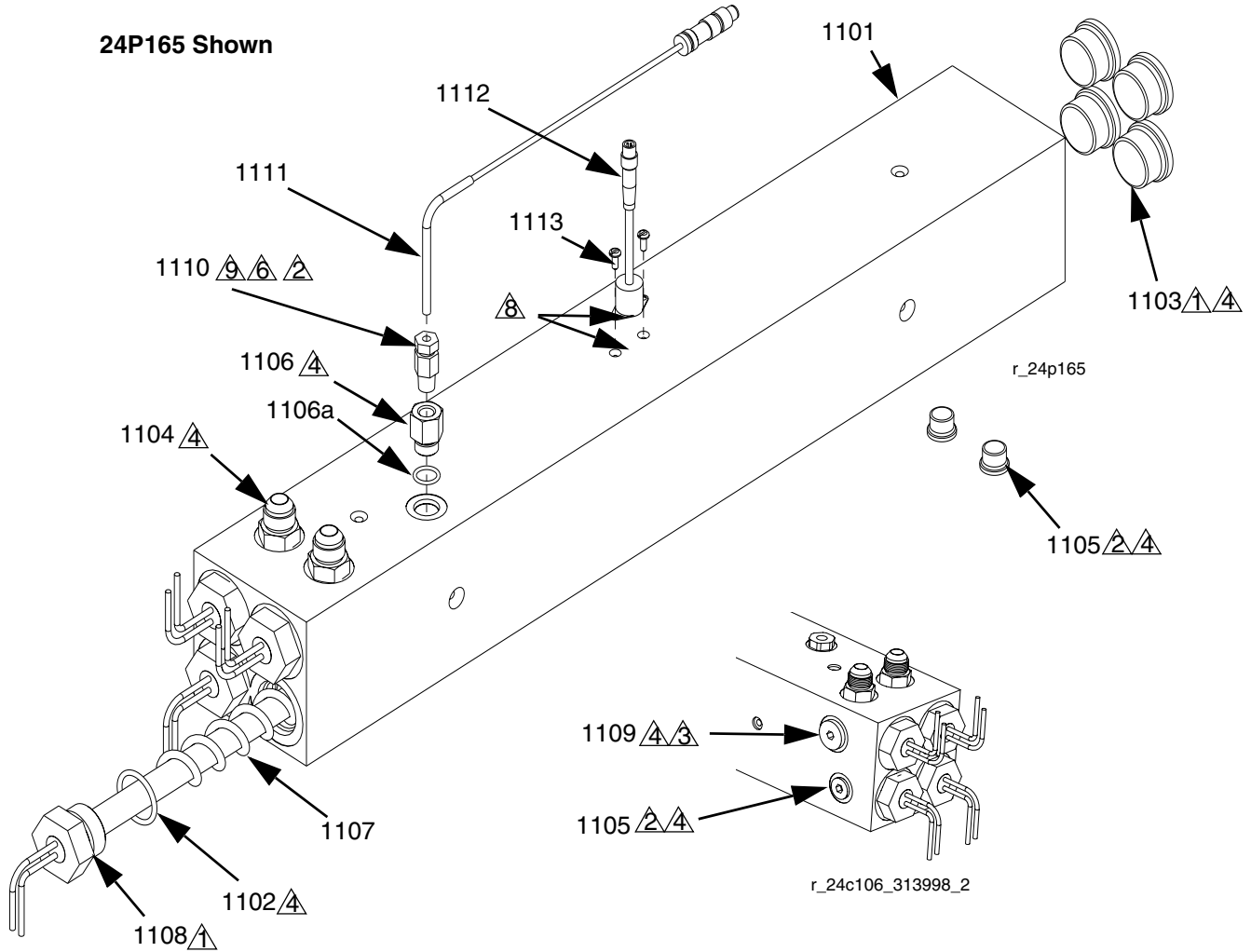

FIG. 23: Heat Power Panel Modules

Ref	Part	Description	Quantity							
			MODULE, panel, pwr, heat, hose, pr, hv	MODULE, panel, pwr, heat, hose, hv	MODULE, panel, pwr, heat, pri, hv	MODULE, panel, pwr, no heat, hv	MODULE, panel, pwr, heat, hose, pr, lv	MODULE, panel, pwr, heat, hose, lv	MODULE, panel, pwr, heat, pri, lv	MODULE, panel, pwr, no heat, lv
1001		PANEL, electric, heat	1	1	1	1	1	1	1	1
1002	255774	MODULE, high power temp, gca	2	1	1		2	1	1	
1003		MODULE, assy, pwr, heat, hose, pri, hv	1							
		MODULE, assy, pwr, heat, hose, hv		1						
		MODULE, assy, pwr, heat, pri, hv			1					
		MODULE, assy, pwr, no heat, hv				1				
		MODULE, assy, pwr, heat, hose, pri, lv					1			
		MODULE, assy, pwr, heat, hose, lv						1		
		MODULE, assy, pwr, heat, pri, lv							1	
		MODULE, assy, pwr, no heat, lv								1
1004	123452	HOLDER, anchor, wire tie, nylon	5	5	4	4	5	5	4	4
1005	116876	WASHER, flat	4	3	3	2	4	3	3	2
1006	103833	SCREW, mach, crbh (matrix)	9	8	7	6	9	8	7	6
1007	125306	CABLE, can, female / female 0.5m	1				1			
1008	100021	SCREW, cap hex hd (matrix)	1	1	1	1	1	1	1	1
1009	100028	WASHER, lock	2	2	2	2	2	2	2	2
1010	100015	NUT, hex mscr	2	2	2	2	2	2	2	2
1011	24C311	HARNESS, wire, pdb, ground	1	1	1	1	1	1	1	1
1012	24C318	HARNESS, wire, pdb, terminal	1	1	1	1	1	1	1	1
1014	24C304	HARNESS, wire, pdb, inline heater	2	1	1		2	1	1	
1015	15R535	BRACKET, mounting, GCA high power	4	2	2		4	2	2	
1016	117831	SCREW, mach., pan hd (matrix)	8	4	4		8	4	4	

**Heater - Aluminum with Carbon Steel Fittings, 24C426**  
**Heater - Aluminum with Stainless Steel Fittings, 24P165**



- $\triangle$  Torque to 120 ft-lb (163 N•m)
- $\triangle$  Torque to 23 ft-lb (31 N•m)
- $\triangle$  Torque to 40 ft-lb (54 N•m)
- $\triangle$  Apply lubricant to o-rings before assembling into heater.
- $\triangle$  Tighten NPT thread at least on turn after RTD has been tightened.
- $\triangle$  Apply thermal paste when assembling thermal switch.
- $\triangle$  Apply sealant and tape to all non swiveling and non o-ring threads.



Ref	Part		Description	Qty
	Assembly 24C426	Assembly 24P165		
1101	15J090	15J090	HEATER, machined, 1 zone, 3500 psi	1
1102	124132	124132	O-RING	4
1103	15H305	126561	FITTING, plug hollow hex 1-3/16 sae	4
1104	121309	126562	FITTING, adapter, sae-orb x jic	2
1105	15H304	126563	FITTING, plug 9/16 sae	3
1106	15H306	126564◆	ADAPTER, thermocouple, 9/16 x 1/8	1
1106a	120336	◆	O-RING, packing	1
1107	15B135	16T320	MIXER, immersion heater	4
1108	16A112	16A112	HEATER, immersion (1500W 230V)	4
1109	295607	561460	PLUG, outlet	1
1110		123325	FITTING, compression, 1/8npt, ss	1
1111		124262	SENSOR, rtd, 1kohm, 90deg, 4pin, tip	1
1112		123408	HARNESS, m8 x thermal switch, 3-pin	1
1113		100518	SCREW, mach, mnhd	2
1115		---	LUBRICANT, thermal	1
1116	---	---	TAPE, tfe, sealant	1
1117	---	---	LUBRICANT, thread	1

--- Not available for individual sale.

◆ Item 1106 include viton o-ring.

# Heater 24J787

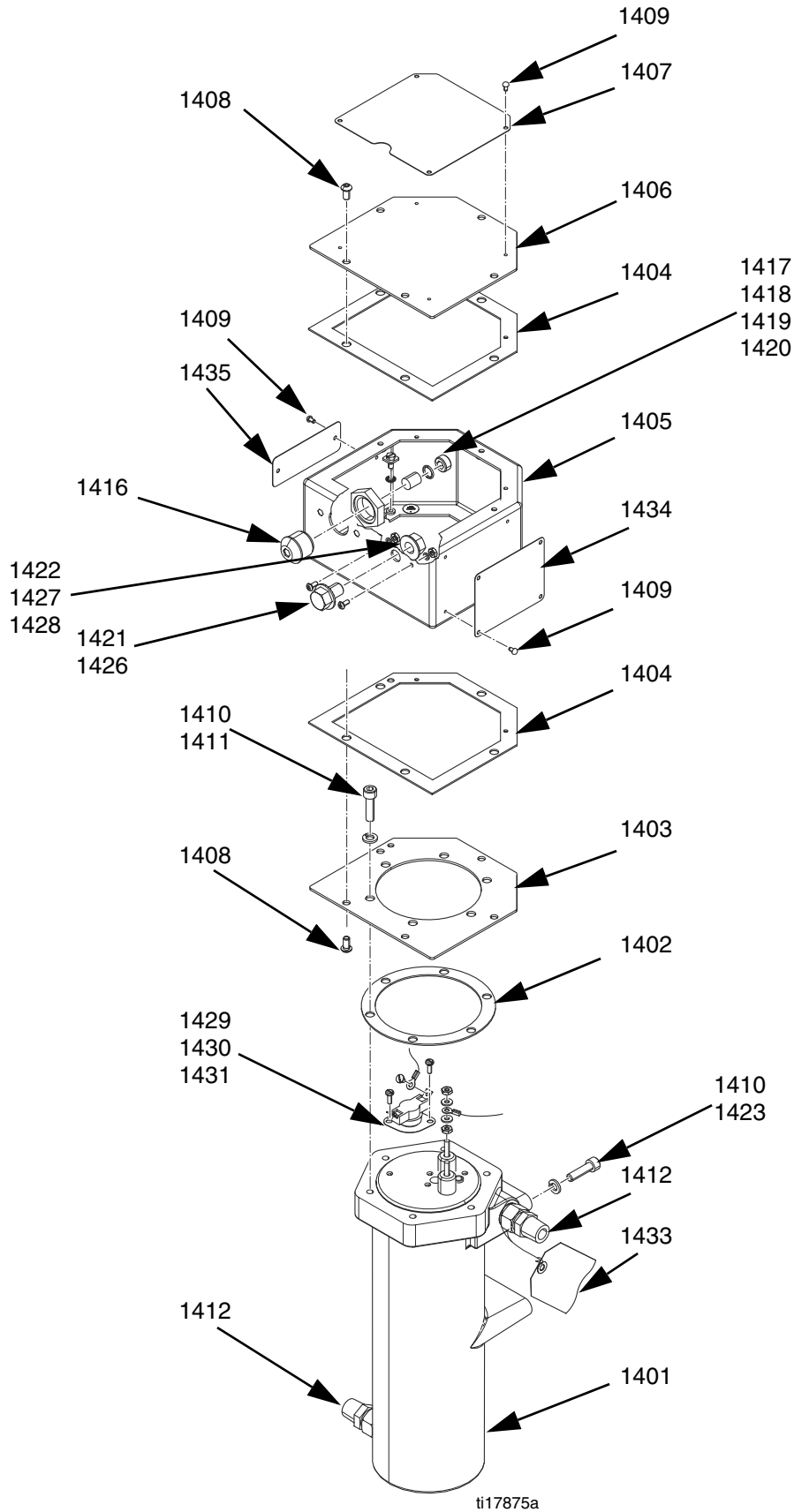

Ref	Part	Description	Qty
1401†	---	BLOCK, heater, machined	1
1402	15A990	GASKET, heater	1
1403	15A811	COVER, heater controls, bottom	1
1404	15A991	GASKET, heater	2
1405	15A809	ENCLOSURE, controls, heater	1
1406	15A810	COVER, heater controls, top	1
1407	15B625	LABEL, plate, warning	1
1408	111962	SCREW, cap, button hd	10
1409	100055	SCREW, drive, #6	10
1410	107542	WASHER, lock, spring	10
1411	117367	SCREW, shcs, m8x18	6
1412†	117344	FITTING, tube, compression	2
1413▲	172953	LABEL, designation	1
1414	111307	WASHER, lock, external	1
1415	116343	SCREW, ground	1
1416	15B828	HOUSING, light, heater, viscon hp	1
1417	106216	NUT, lock	1
1418	15B827	LENS, light, glass	1
1419	103338	PACKING, o-ring	1
1420	117483	SCREW, jam, socket	1
1421	111802	SCREW, cap, hex hd	1
1422	112731	NUT, hex, flanged	1
1423	109114	SCREW, cap, sch	4
1424	100166	NUT, full hex	4
1425	102360	WASHER, flat	4
1426	15U075	SCREW, cap, bh, 8-32 x .37	2
1427	555388	NUT, # 8-32 hex	2
1428	100079	WASHER, lock, spring	2
1429	108674	THERMOSTAT	1
1430	105676	SCREW, mach, pnh	2
1431	073019	LUBRICANT, thermal	1
1432	235524	WIRE, assy	1
1433▲	177922	TAG, warning	1
1434▲	16K138	LABEL, brand, viscon hp, nvh	1
1435▲	15B623	LABEL, plate, des, viscon hp	1
1442▲	15B777	LABEL, warning, viscon hp	1
1443▲	15B819	LABEL, warning, viscon hp	1

▲ *Replacement Danger and Warning labels, tags and cards are available at no cost.*

--- Not for individual sale

† Items available for purchase in kit 24K290

# Kits

## DC Power Pack Pressure Adjustment Kit, 24C067

This kit provides a release for excess pressure in the hydraulic system. It must be installed if a Fusion or P2 gun is used.

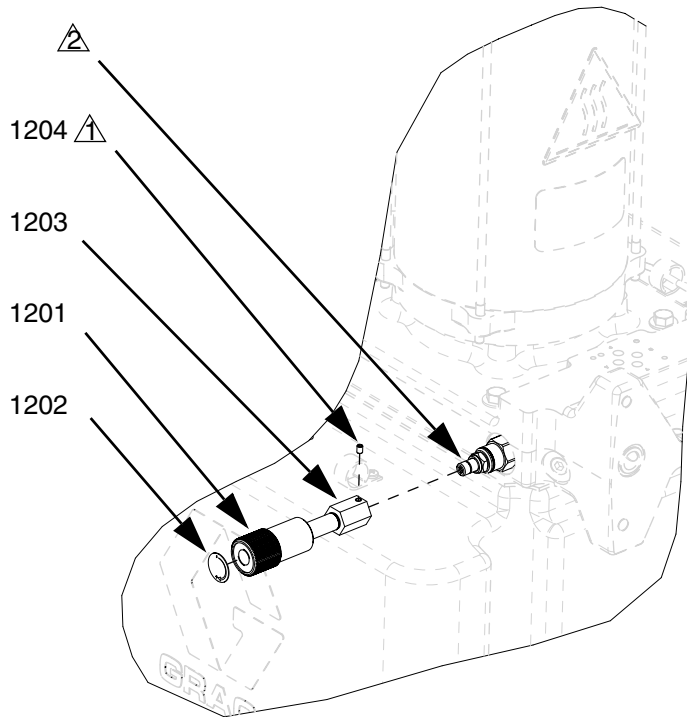

 Torque to 23 in-lb (2.6 N•m).

 Part is reference number 15 in hydraulic power pack assembly. See **Hydraulic DC Power Pack Module** on page 54.

Ref	Part	Description	Qty
1201	15H204	KNOB, pressure adjustment	1
1202	15H512	LABEL, control, H25	1
1203	15Y370	ADAPTER, pressure relief	1
1204	116624	SCREW, set, socket head	1

## DC Power Pack Hydraulic Pressure Adjustment Setup



This procedure requires running the machine with the hydraulic power pack shroud removed. Be sure to avoid contact with the fan while the machine is on.

This kit provides a release for excess pressure in the hydraulic system. It must be installed if a Fusion or P2 gun is used.

1. Perform **Shutdown** on page 21.
2. **Remove Hydraulic Power Pack Shroud**, page 33.
3. Install pressure relief kit 24C067.  
**NOTE:** Prior to installing pressure adjustment knob (1201), use a 9/16 in. wrench to back the jam nut (1203) all the way out until it stops.
4. Turn the pressure adjustment knob (1201) clockwise until it stops.
5. Turn the pressure adjustment knob counter-clockwise two full turns.
6. Turn main power switch to ON position.
7. Setup the machine to spray in Operator mode. See HFR operation manual 313997 if necessary.

8. While watching the ADM and listening to the motor, begin spraying material.

**NOTE:** If the ADM displays an overpressure situation, the relief pressure is set too high.

**NOTE:** If it sounds like the motor is spinning too fast and/or it sounds like hydraulic fluid is being dumped back to the tank, the relief pressure is set too low.

9. **If the relief pressure is set too high:** Clear the over pressure warning on the ADM then turn the pressure adjustment knob counterclockwise 1/4 turn. See HFR operation manual 313997 if necessary.

**If the relief pressure is set too low:** Turn the pressure adjustment knob clockwise 1/4 turn.

10. Repeat the previous two steps until the relief pressure is correctly set.

# Logic Drawings

## 230V, 1 Phase, No Heat

LOCATED IN THE MAIN PDB ENCLOSURE  
 CUSTOMER MUST SUPPLY BRANCH CIRCUIT PROTECTION

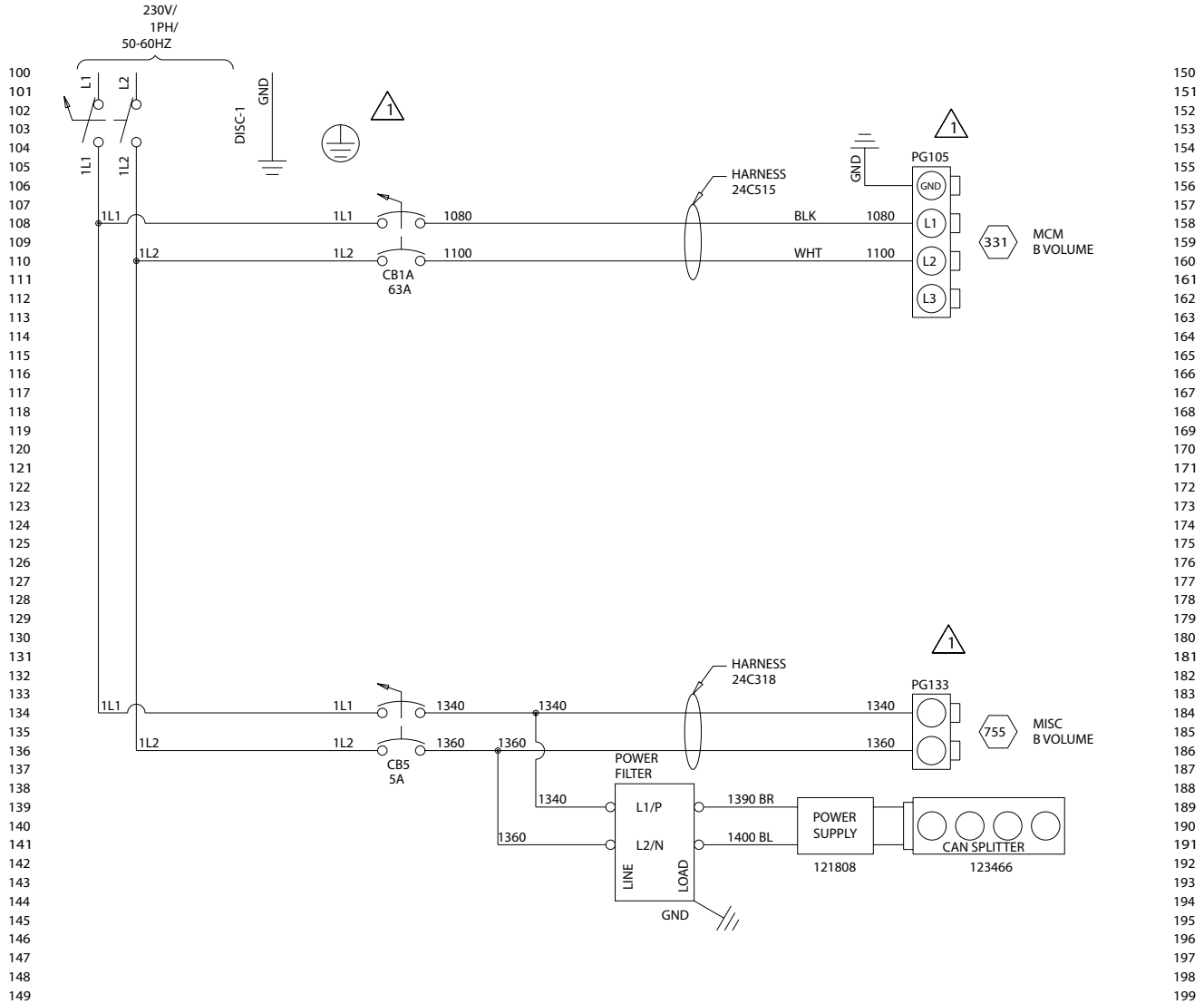

Fig. 24: 230V, 1 Phase, No Heat Logic Drawing; Page 1 of 1

# 230V, 1 Phase, with Heat

LOCATED IN THE MAIN PDB ENCLOSURE  
 CUSTOMER MUST SUPPLY BRANCH CIRCUIT PROTECTION

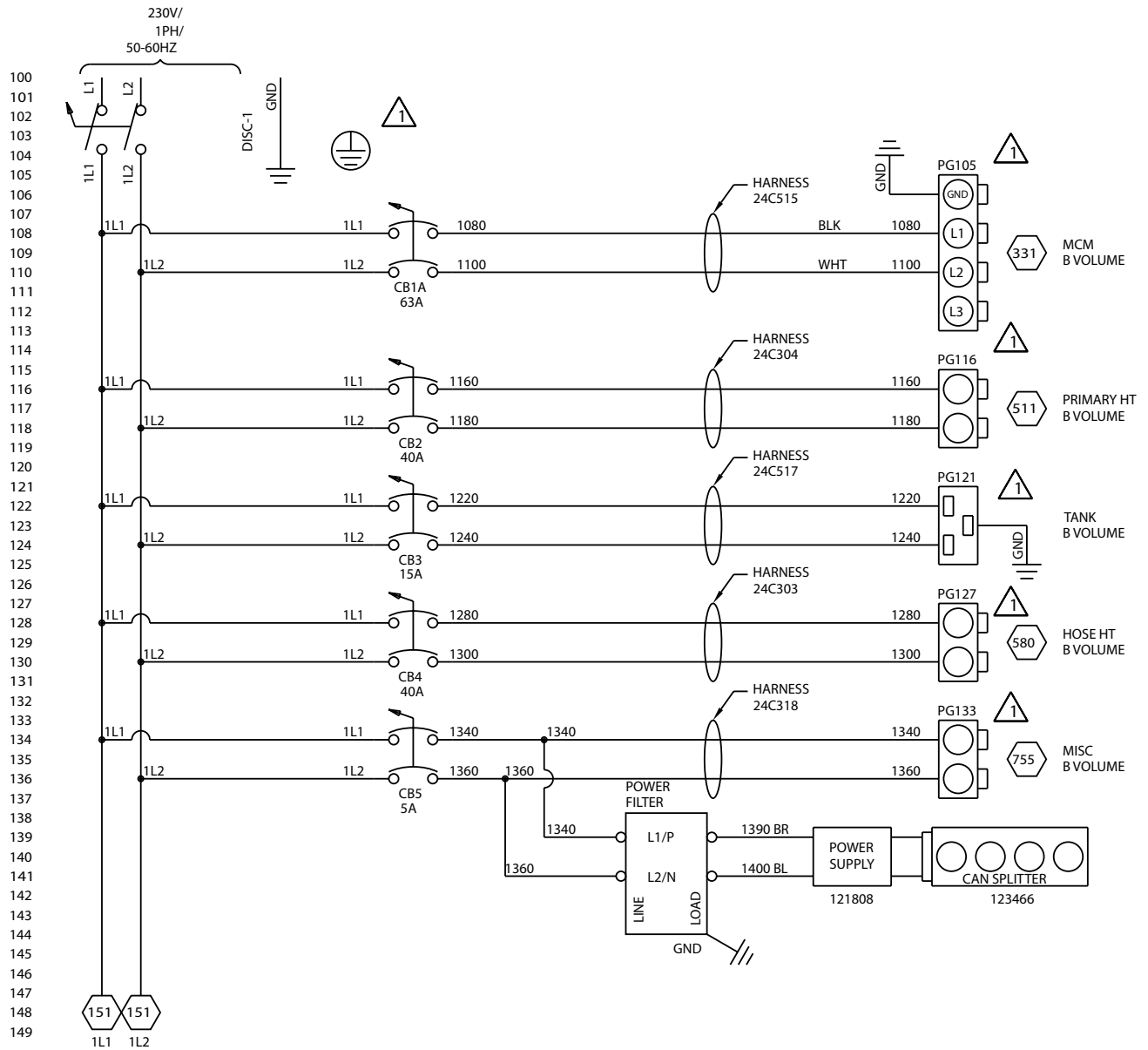

FIG. 25: 230V, 1 Phase, with Heat Logic Drawing; Page 1 of 2

150  
151  
152  
153  
154  
155  
156  
157  
158  
159  
160  
161  
162  
163  
164  
165  
166  
167  
168  
169  
170  
171  
172  
173  
174  
175  
176  
177  
178  
179  
180  
181  
182  
183  
184  
185  
186  
187  
188  
189  
190  
191  
192  
193  
194  
195  
196  
197  
198  
199

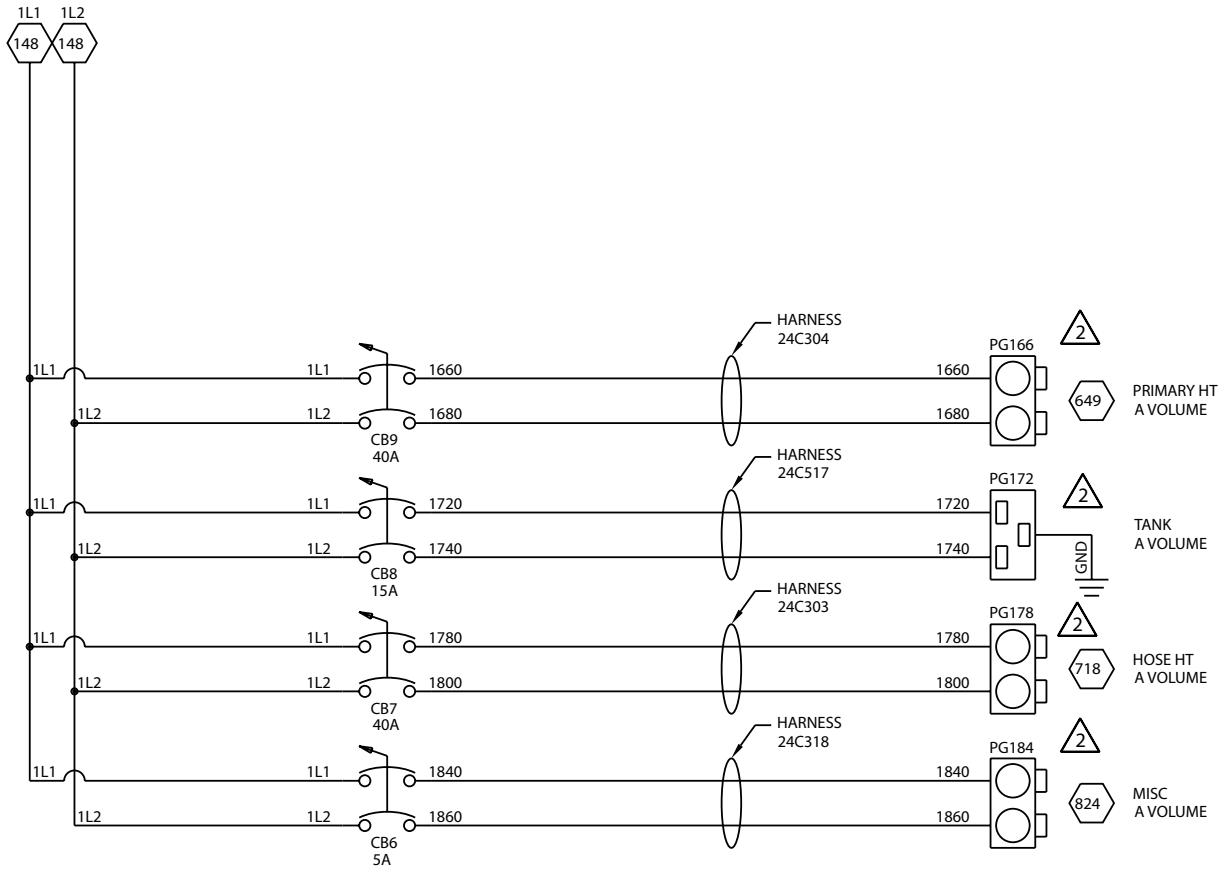

FIG. 26: 230V, 1 Phase, with Heat Logic Drawing; Page 2 of 2



# 230V, 3 Phase, No Heat

LOCATED IN THE MAIN PDB ENCLOSURE  
 CUSTOMER MUST SUPPLY BRANCH CIRCUIT PROTECTION

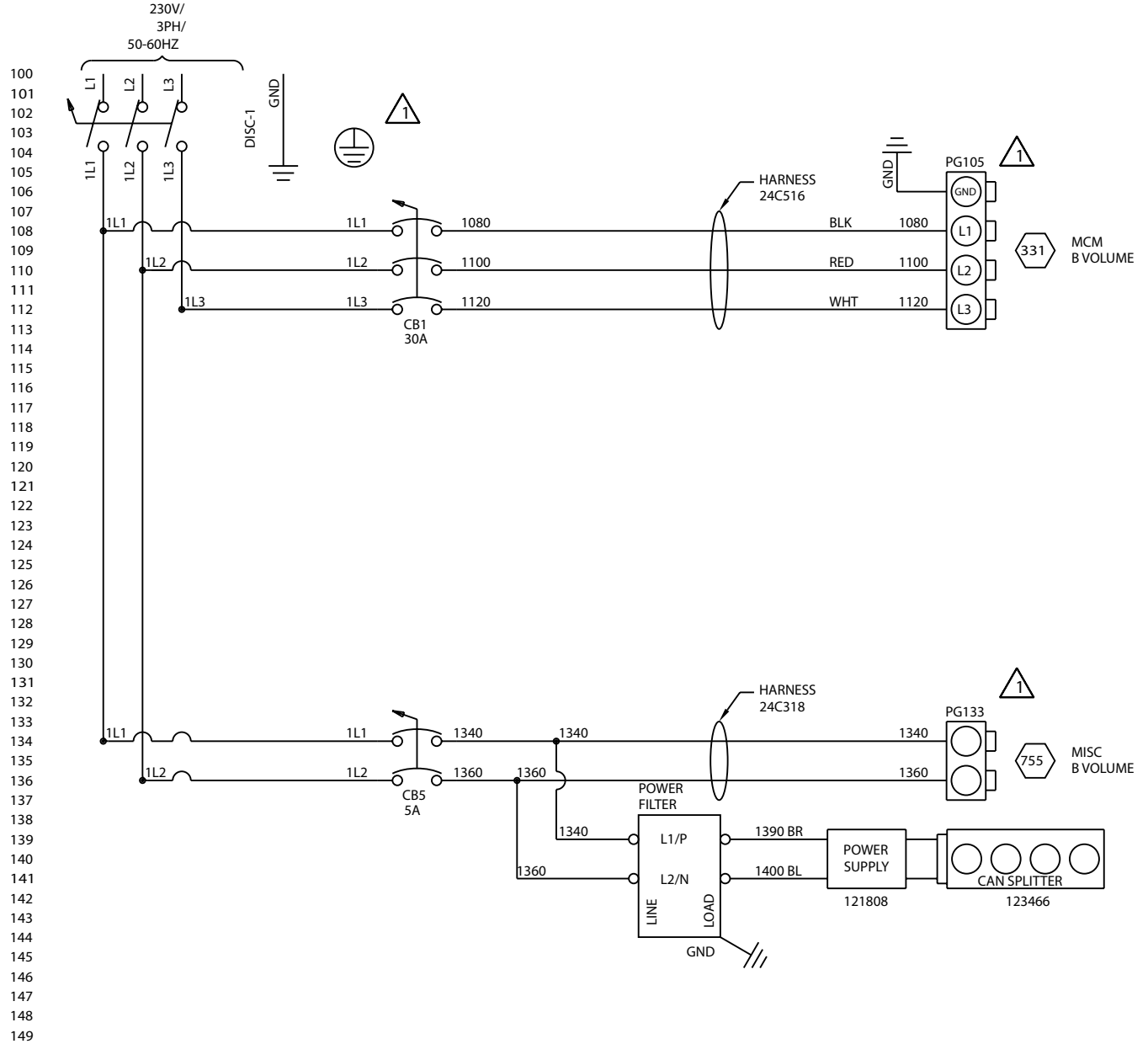

FIG. 27: 230V, 3 Phase, No Heat Logic Drawing; Page 1 of 1

# 230V, 3 Phase, with Heat

LOCATED IN THE MAIN PDB ENCLOSURE  
 CUSTOMER MUST SUPPLY BRANCH CIRCUIT PROTECTION

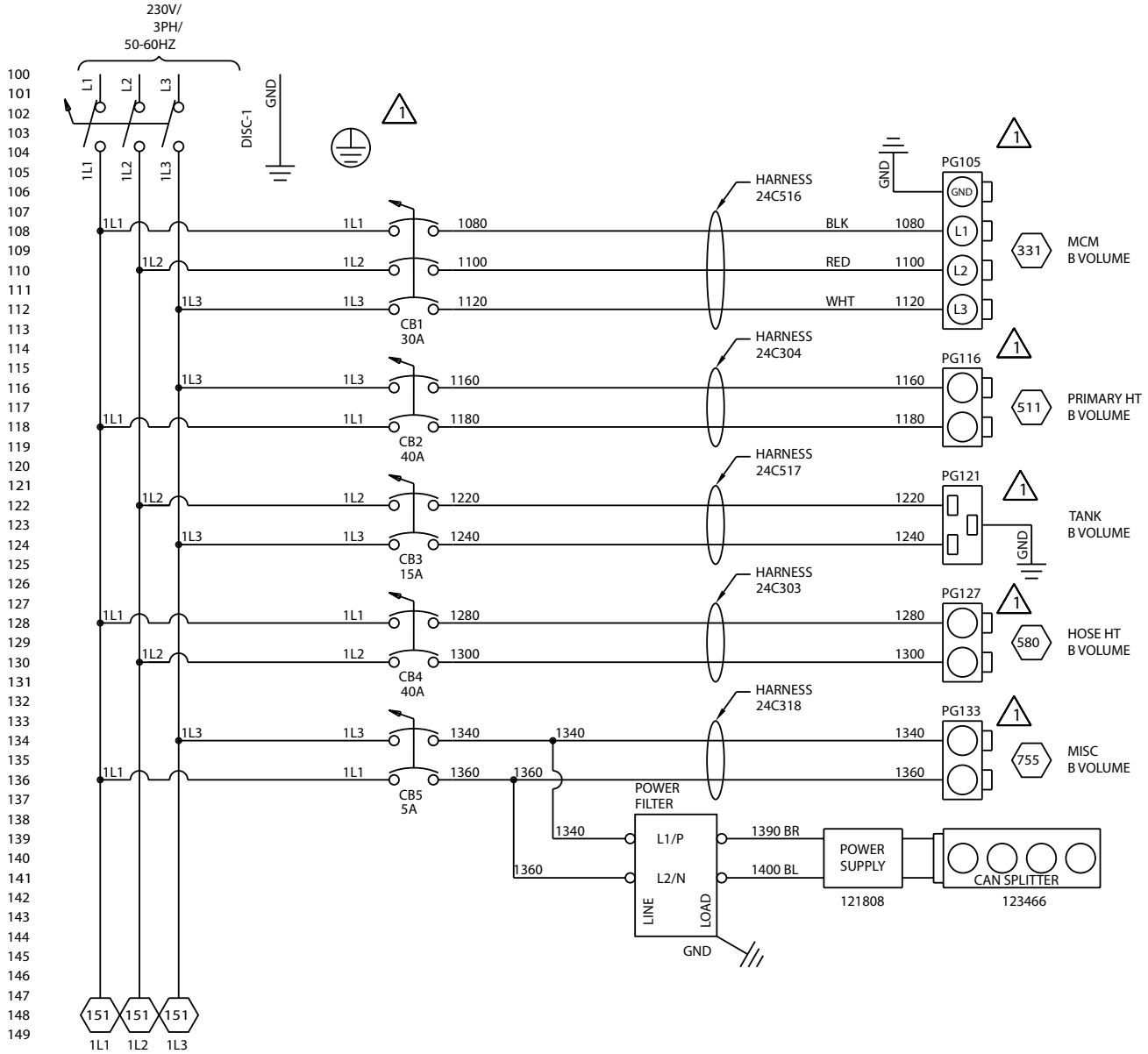

FIG. 28: 230V, 3 Phase, with Heat Logic Drawing; Page 1 of 2

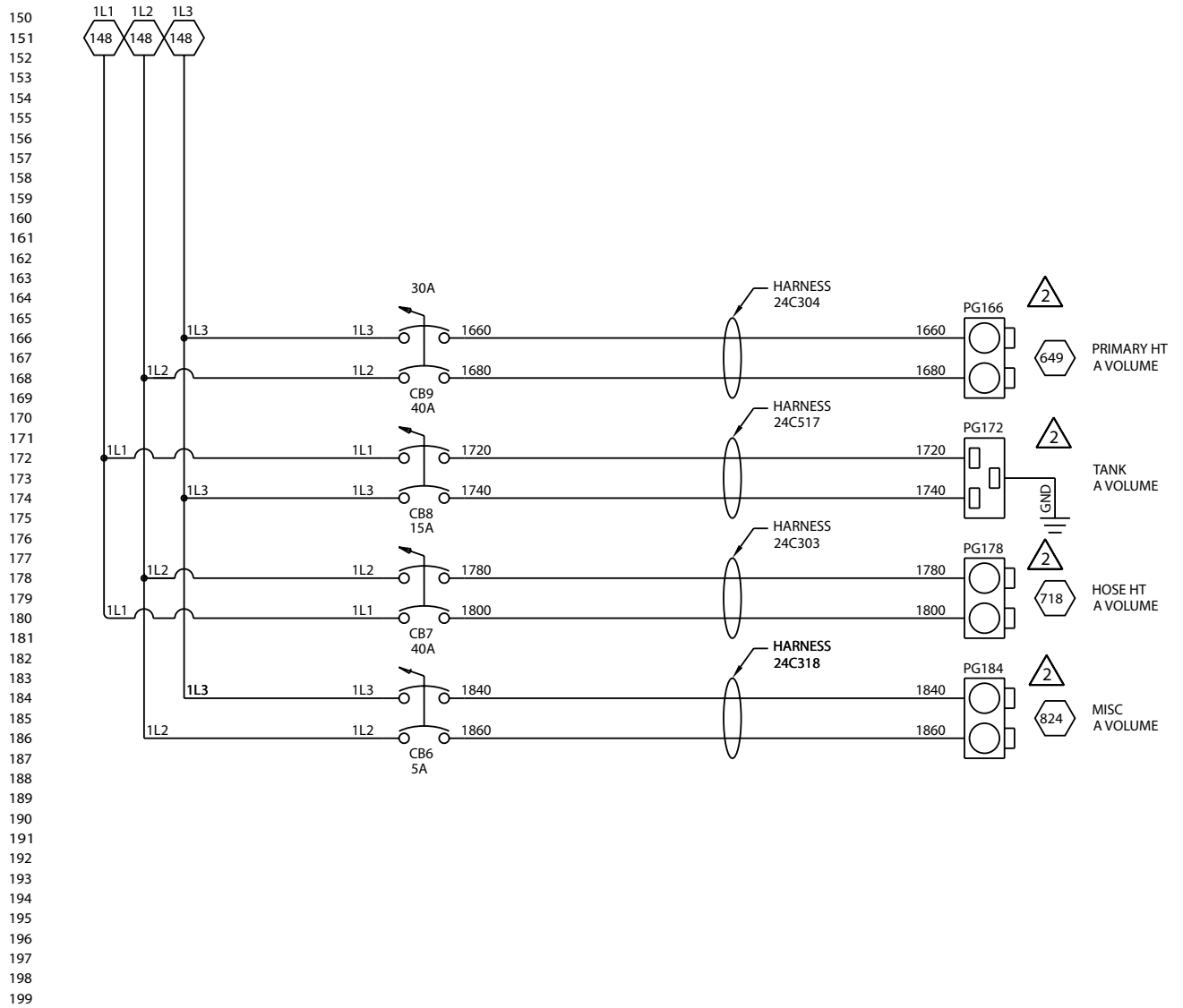

FIG. 29: 230V, 3 Phase, with Heat Logic Drawing; Page 2 of 2

# 400V, 3 Phase, No Heat

LOCATED IN THE MAIN PDB ENCLOSURE  
 CUSTOMER MUST SUPPLY BRANCH CIRCUIT PROTECTION

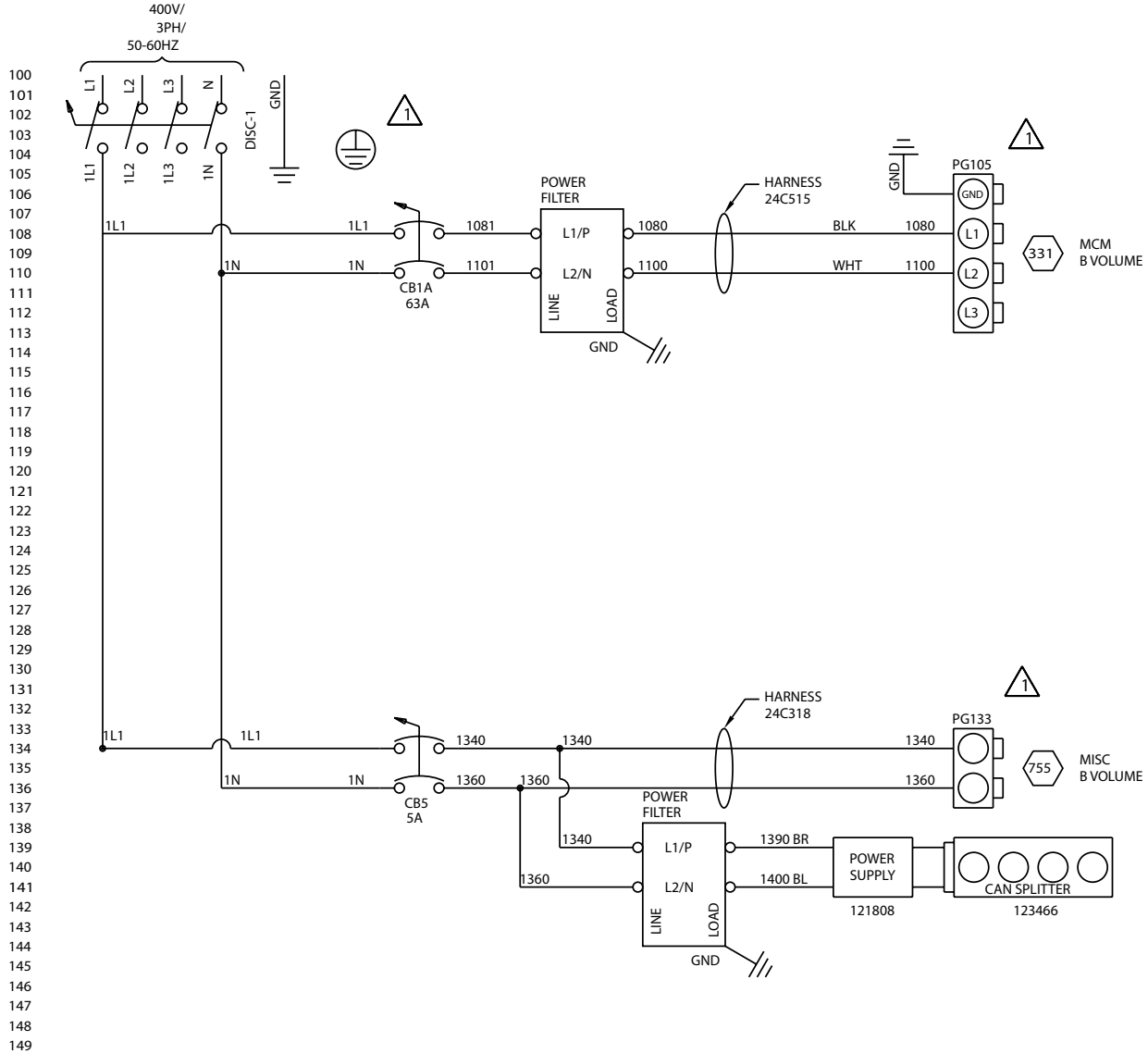

FIG. 30: 400V, 3 Phase, No Heat Logic Drawing; Page 1 of 1

# 400V, 3 Phase, with Heat

LOCATED IN THE MAIN PDB ENCLOSURE  
 CUSTOMER MUST SUPPLY BRANCH CIRCUIT PROTECTION

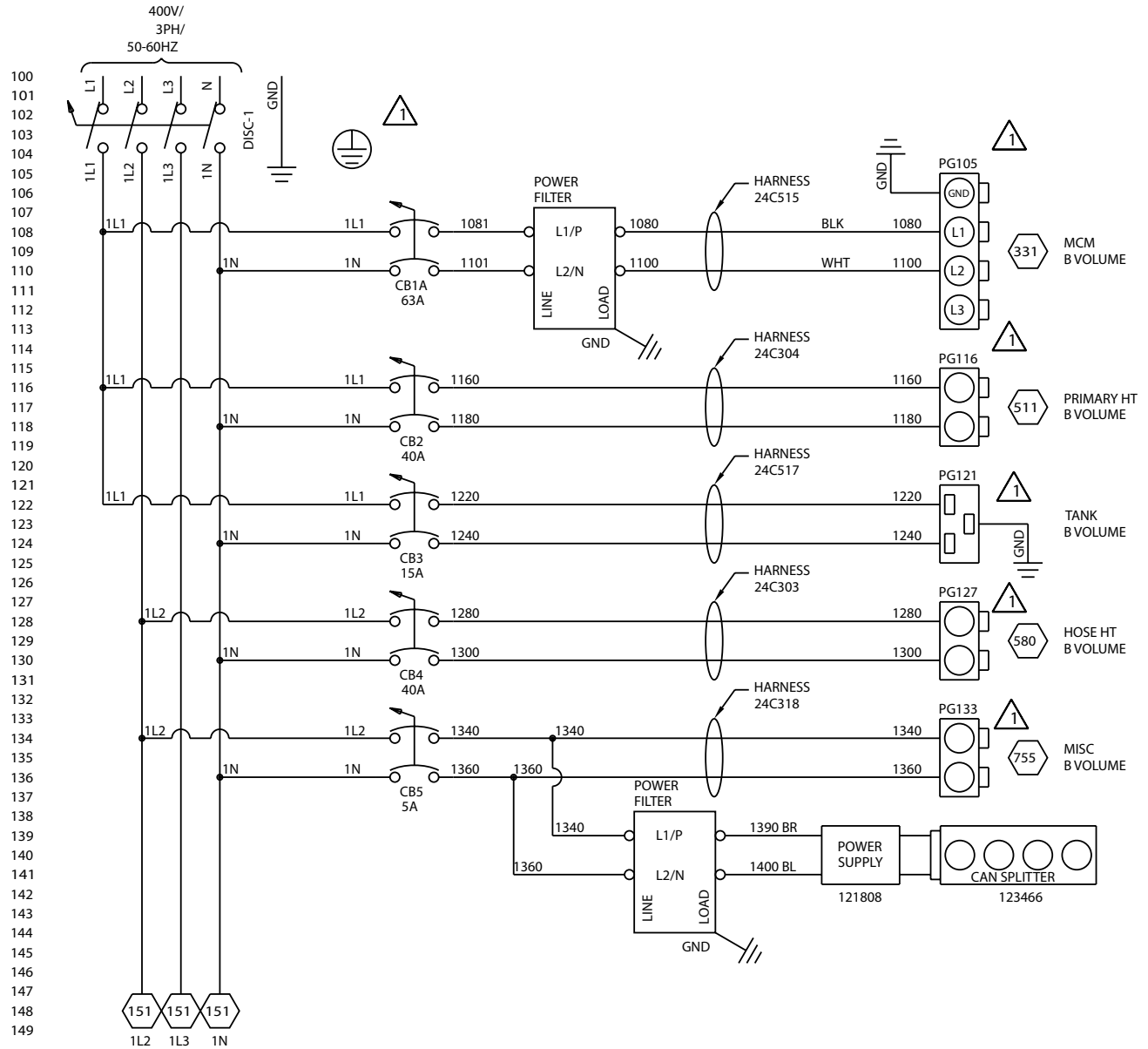

FIG. 31: 400V, 3 Phase, with Heat Logic Drawing; Page 1 of 2

150  
151  
152  
153  
154  
155  
156  
157  
158  
159  
160  
161  
162  
163  
164  
165  
166  
167  
168  
169  
170  
171  
172  
173  
174  
175  
176  
177  
178  
179  
180  
181  
182  
183  
184  
185  
186  
187  
188  
189  
190  
191  
192  
193  
194  
195  
196  
197  
198  
199

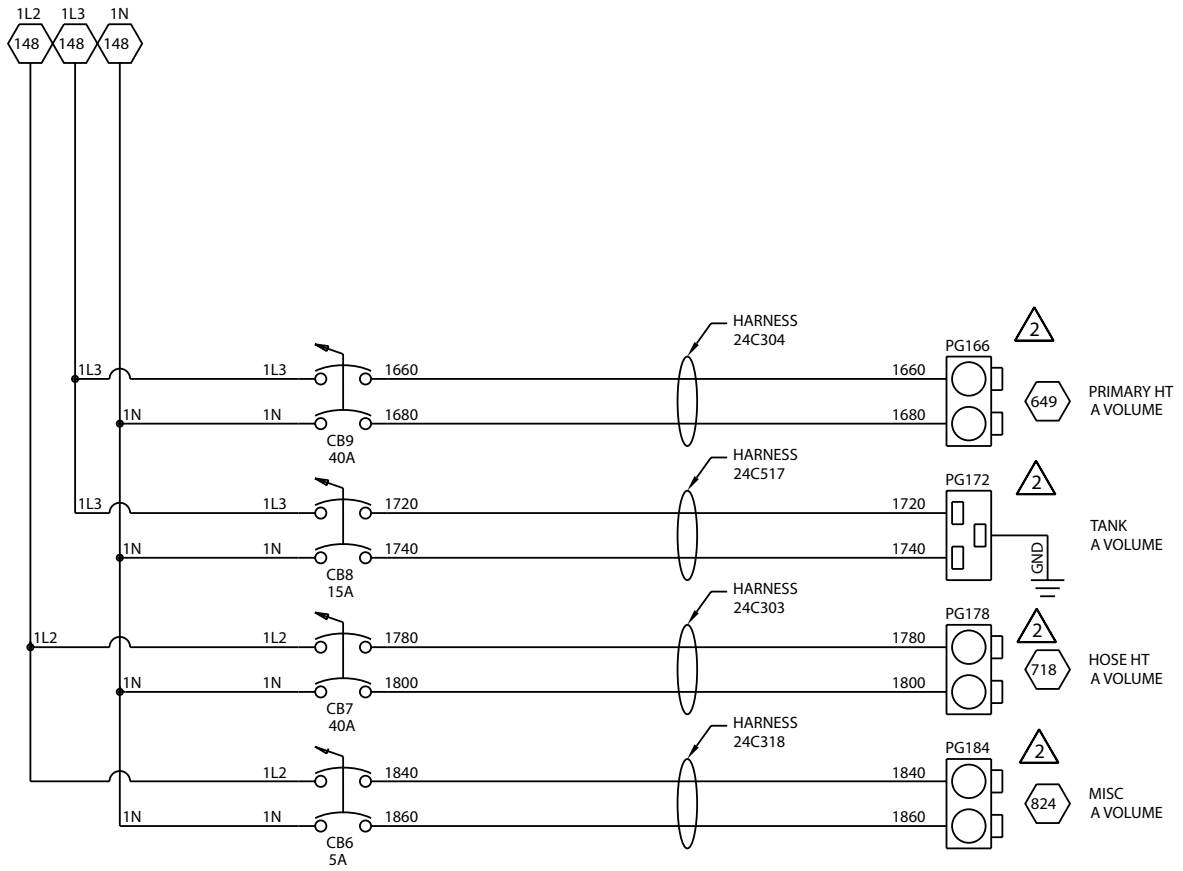

FIG. 32: 400V, 3 Phase, with Heat Logic Drawing; Page 2 of 2

# A (Red) Heat

614  
615  
616  
617  
618  
619  
620  
621  
622  
623  
624  
625  
626  
627  
628  
629  
630  
631  
632  
633  
634  
635  
636  
637  
638  
639  
640  
641  
642  
643  
644  
645  
646  
647  
648  
649  
650  
651  
652  
653  
654  
655  
656  
657  
658  
659  
660  
661  
662  
663  
664  
665  
666  
667  
668  
669  
670  
671  
672  
673  
674  
675  
676  
677  
678  
679  
680  
681  
682

LOCATED IN THE MAIN  
SUPPORT ENCLOSURE

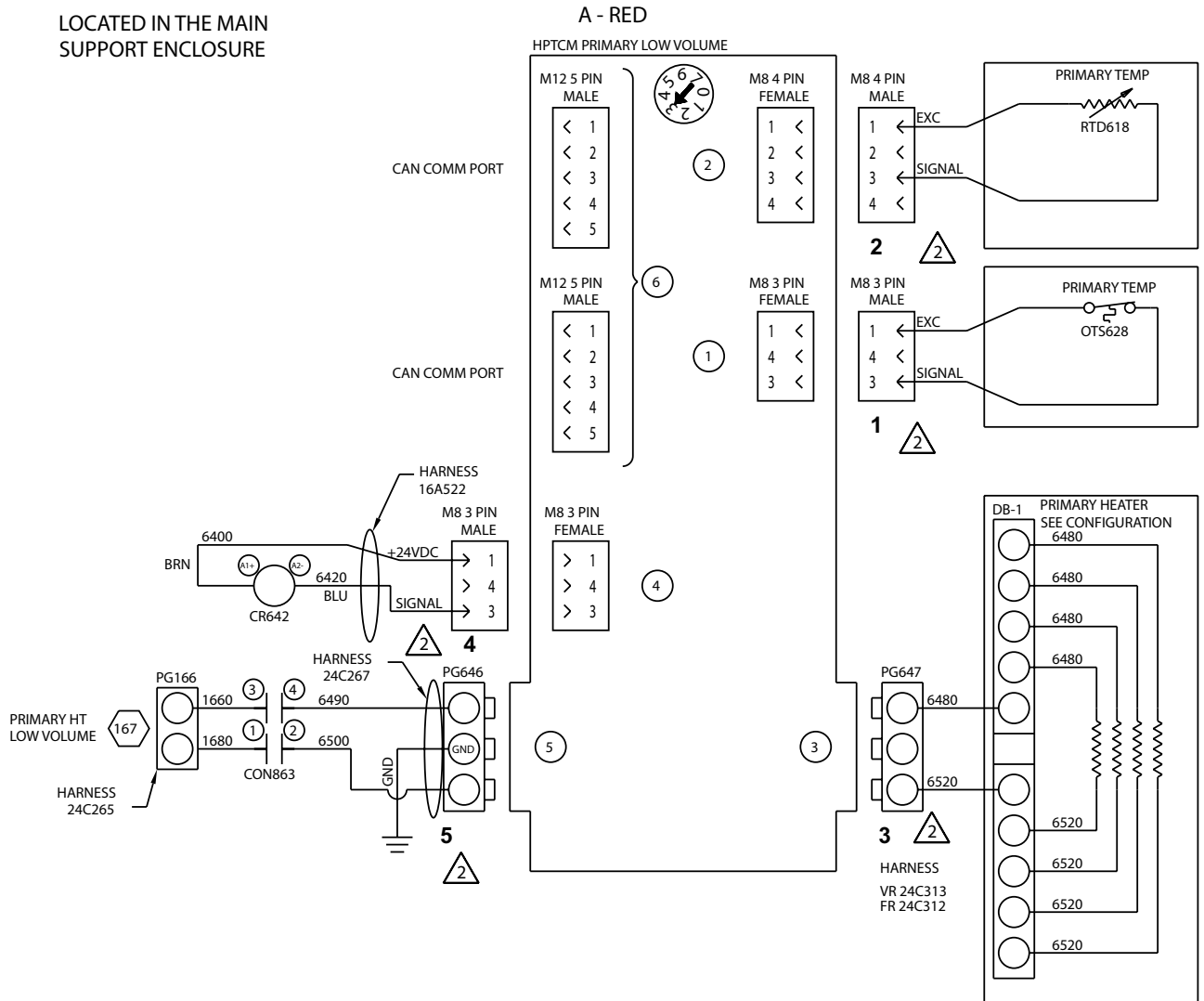

FIG. 33: A (Red) Heat Logic Drawing, Page 1 of 2

683  
684  
685  
686  
687  
688  
689  
690  
691  
692  
693  
694  
695  
696  
697  
698  
699  
700  
701  
702  
703  
704  
705  
706  
707  
708  
709  
710  
711  
712  
713  
714  
715  
716  
717  
718  
719  
720  
721  
722  
723  
724  
725  
726  
727  
728  
729  
730  
731  
732  
733  
734  
735  
736  
737  
738  
739  
740  
741  
742  
743  
744  
745  
746  
747  
748  
749  
750  
751

LOCATED IN THE MAIN  
SUPPORT ENCLOSURE

A - RED

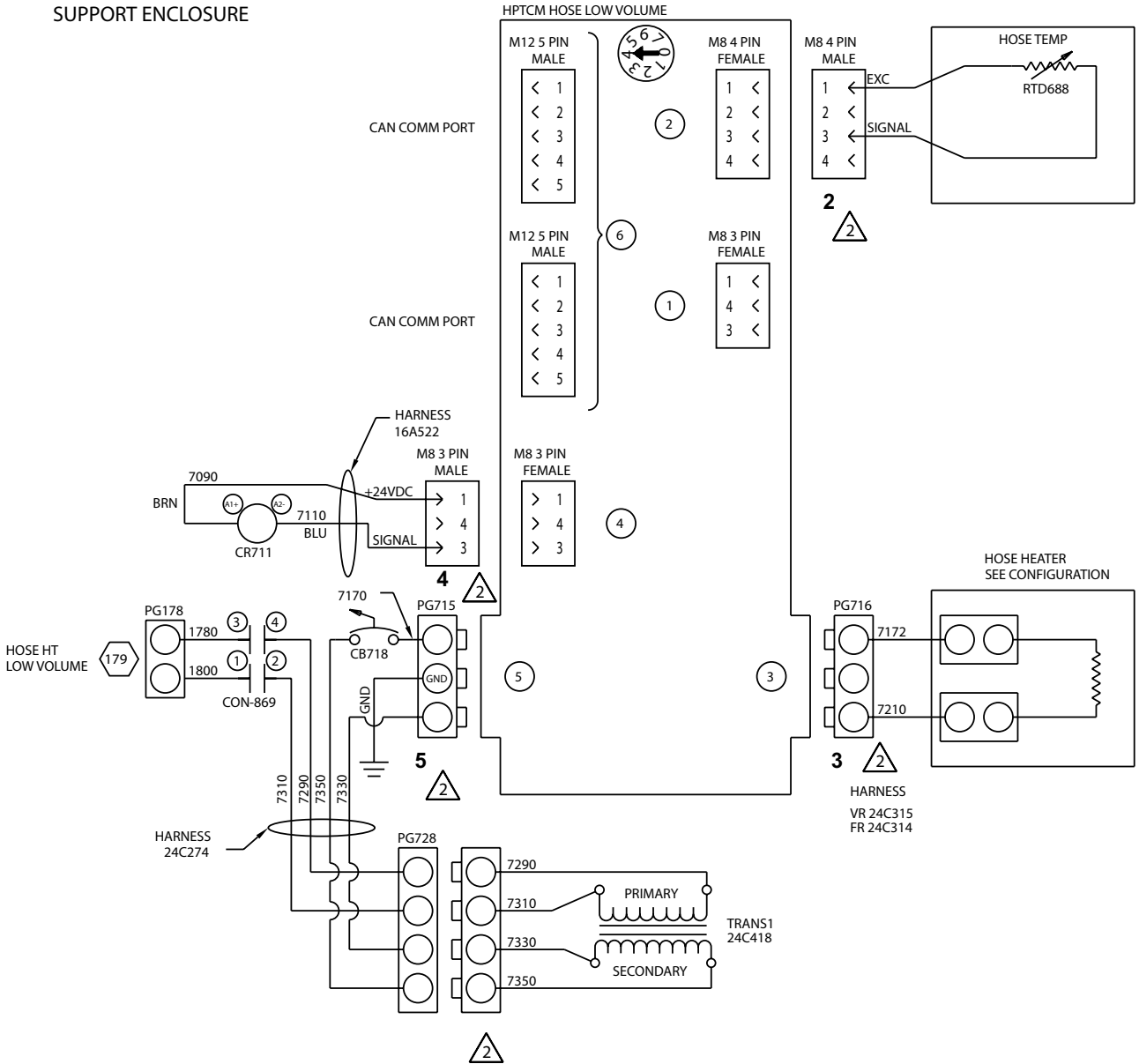

FIG. 34: A (Red) Heat Logic Drawing, Page 2 of 2



# B (Blue) Heat

476  
477  
478  
479  
480  
481  
482  
483  
484  
485  
486  
487  
488  
489  
490  
491  
492  
493  
494  
495  
496  
497  
498  
499  
500  
501  
502  
503  
504  
505  
506  
507  
508  
509  
510  
511  
512  
513  
514  
515  
516  
517  
518  
519  
520  
521  
522  
523  
524  
525  
526  
527  
528  
529  
530  
531  
532  
533  
534  
535  
536  
537  
538  
539  
540  
541  
542  
543  
544

LOCATED IN THE MAIN  
SUPPORT ENCLOSURE

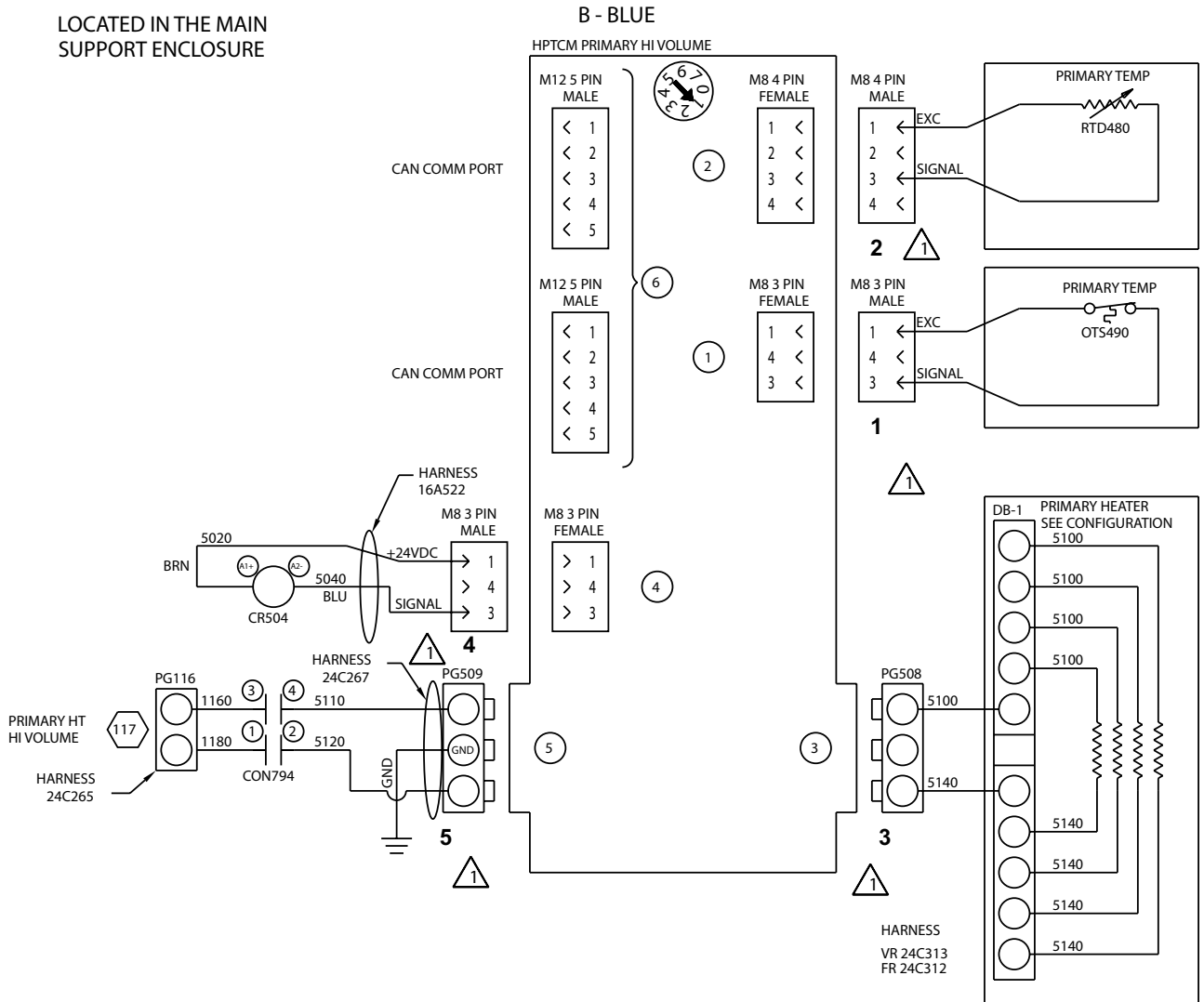

FIG. 35: B (Blue) Heat Logic Drawing, Page 1 of 2

545  
546  
547  
548  
549  
550  
551  
552  
553  
554  
555  
556  
557  
558  
559  
560  
561  
562  
563  
564  
565  
566  
567  
568  
569  
570  
571  
572  
573  
574  
575  
576  
577  
578  
579  
580  
581  
582  
583  
584  
585  
586  
587  
588  
589  
590  
591  
592  
593  
594  
595  
596  
597  
598  
599  
600  
601  
602  
603  
604  
605  
606  
607  
608  
609  
610  
611  
612  
613

LOCATED IN THE MAIN  
SUPPORT ENCLOSURE

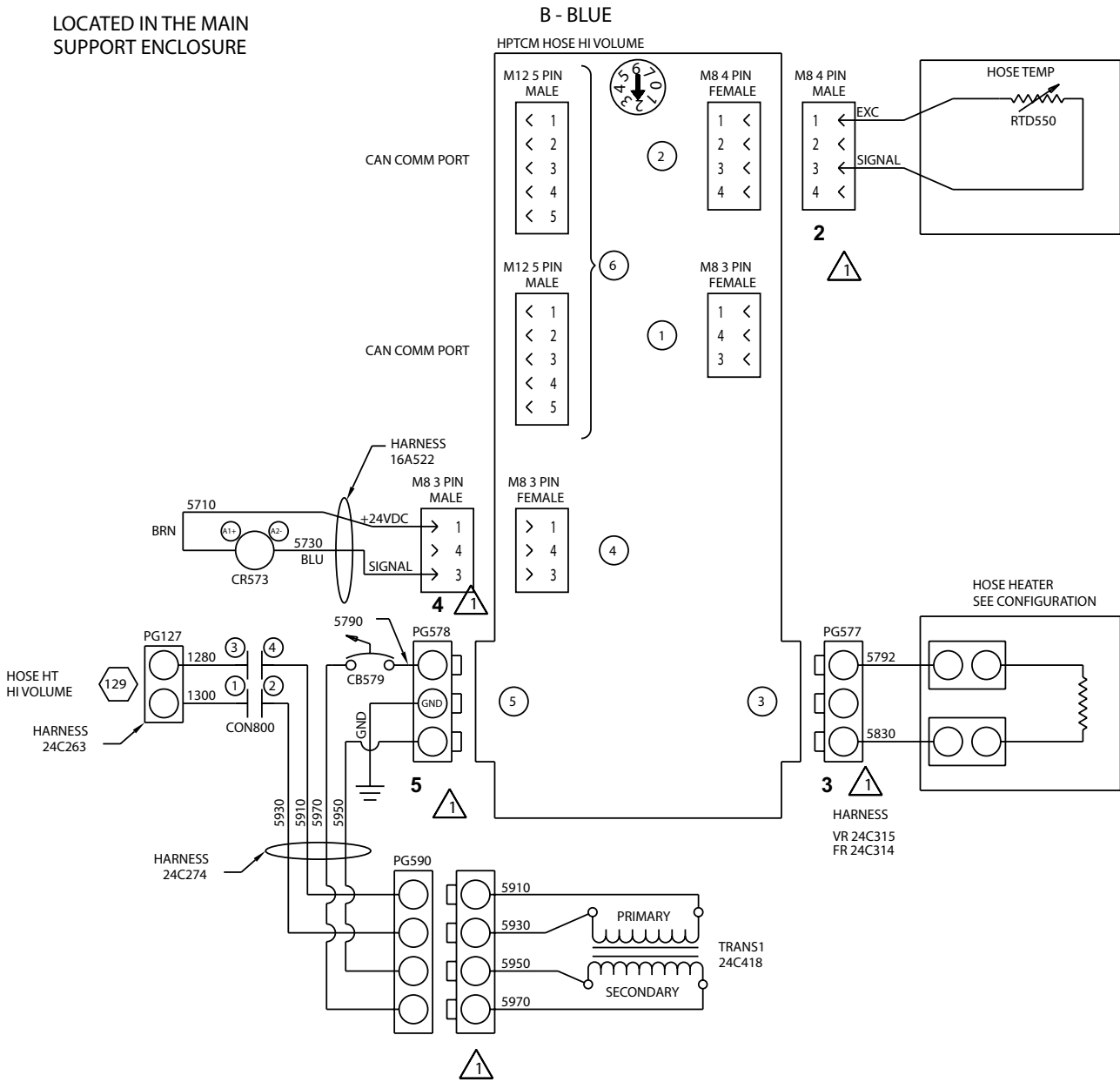

Fig. 36: B (Blue) Heat Logic Drawing, Page 2 of 2

# DC Hydraulic Power Pack

890  
891  
892  
893  
894  
895  
896  
897  
898  
899  
900  
901  
902  
903  
904  
905  
906  
907  
908  
909  
910  
911  
912  
913  
914  
915  
916  
917  
918  
919  
920  
921  
922  
923  
924  
925  
926  
927  
928  
929  
930  
931  
932  
933  
934  
935  
936  
937  
938  
939  
940  
941  
942  
943  
944  
945  
946  
947  
948  
949  
950  
951  
952  
953  
954  
955  
956  
957  
958

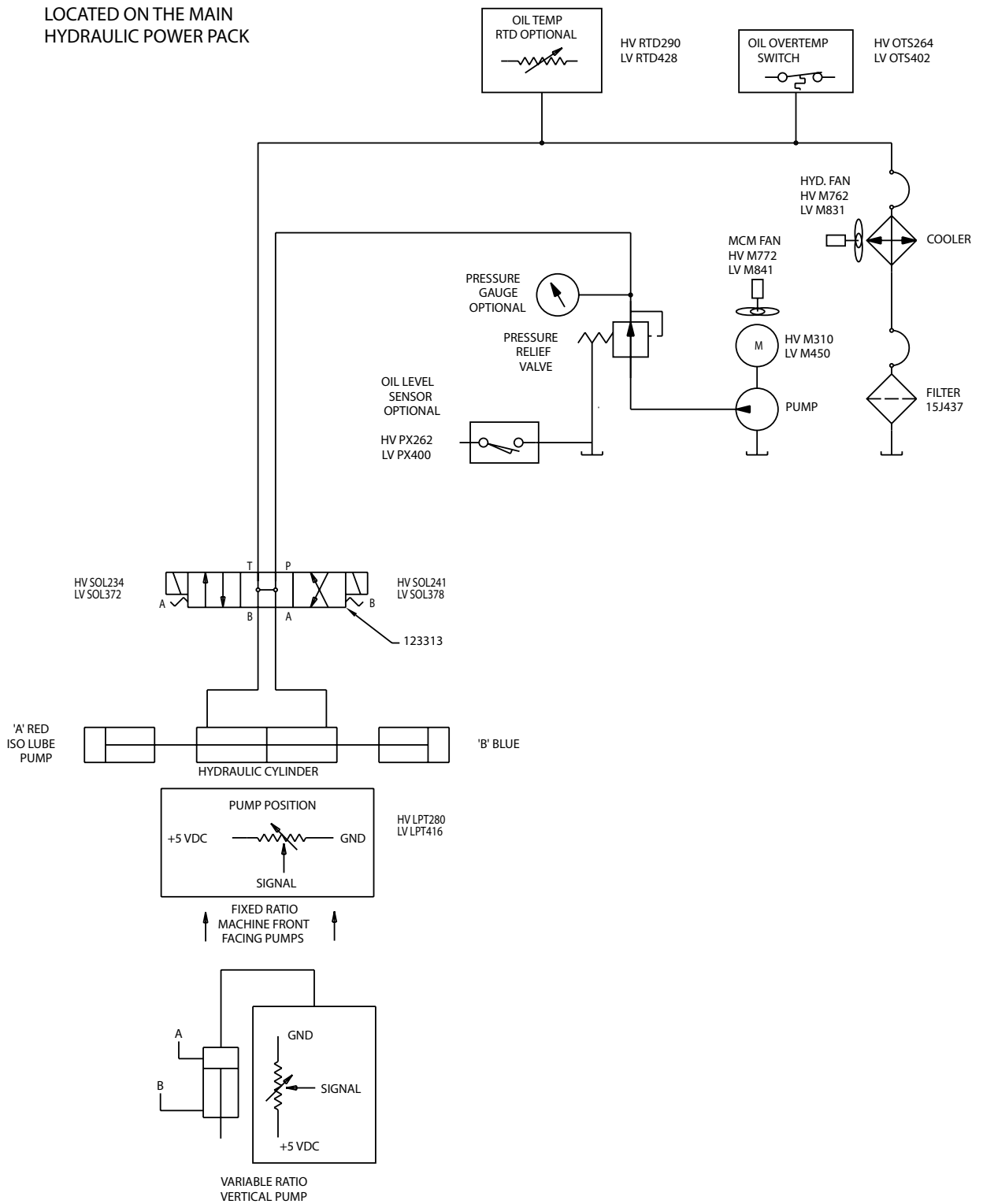

FIG. 37: DC Hydraulic Power Pack Logic Drawing, Page 1 of 1

# Motor Control Module (MCM)

200 LOCATED ON THE HYDRAULIC  
201 POWER PACK - FIXED RATIO  
202



210  
211  
212 CAN COMM PORT  
213  
214  
215  
216  
217  
218  
219  
220  
221  
222  
223  
224  
225  
226  
227  
228  
229  
230

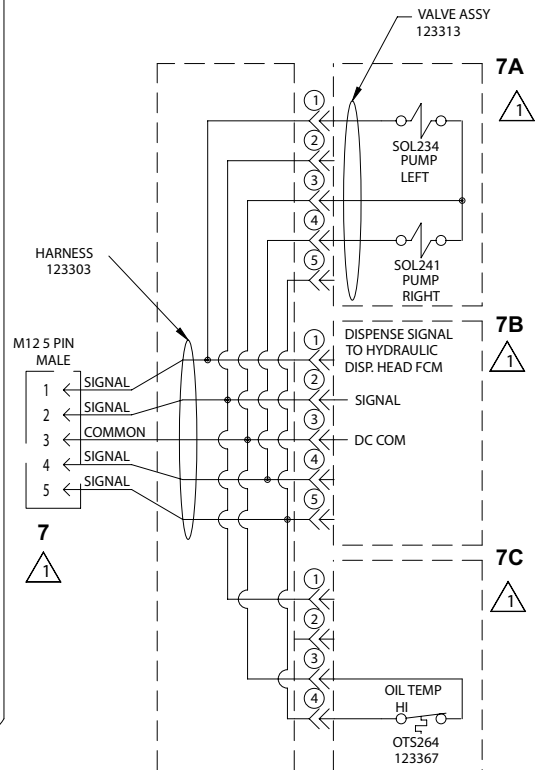
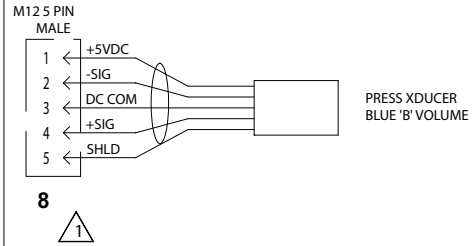
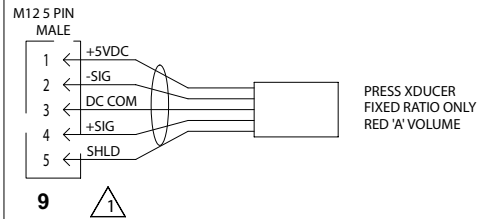
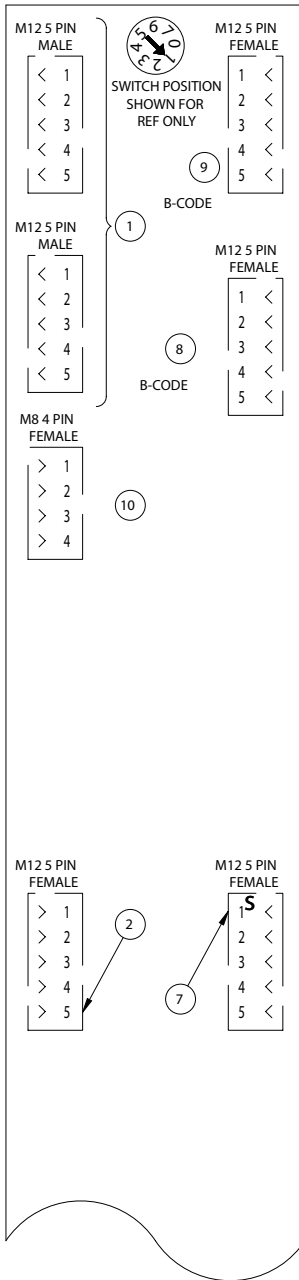
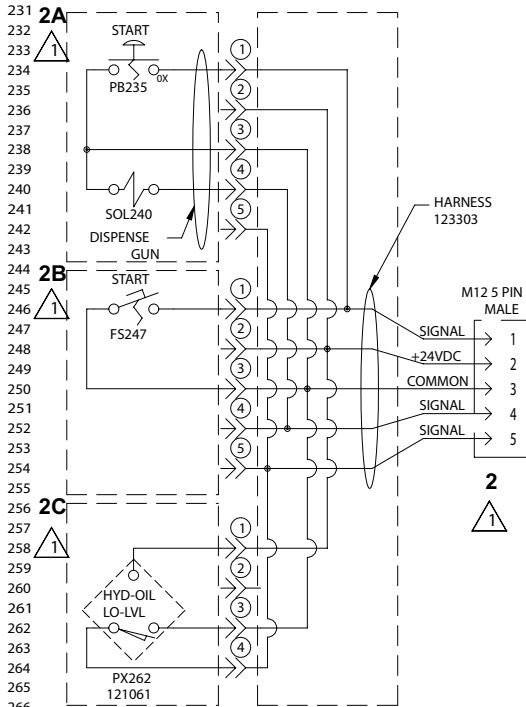

FIG. 38: Motor Control Module (MCM) Logic Drawing, Page 1 of 2

269  
270  
271  
272  
273  
274  
275  
276  
277  
278  
279  
280  
281  
282  
283  
284  
285  
286  
287  
288  
289  
290  
291  
292  
293  
294  
295  
296  
297  
298  
299  
300  
301  
302  
303  
304  
305  
306  
307  
308  
309  
310  
311  
312  
313  
314  
315  
316  
317  
318  
319  
320  
321  
322  
323  
324  
325  
326  
327  
328  
329  
330  
331  
332  
333  
334  
335  
336  
337

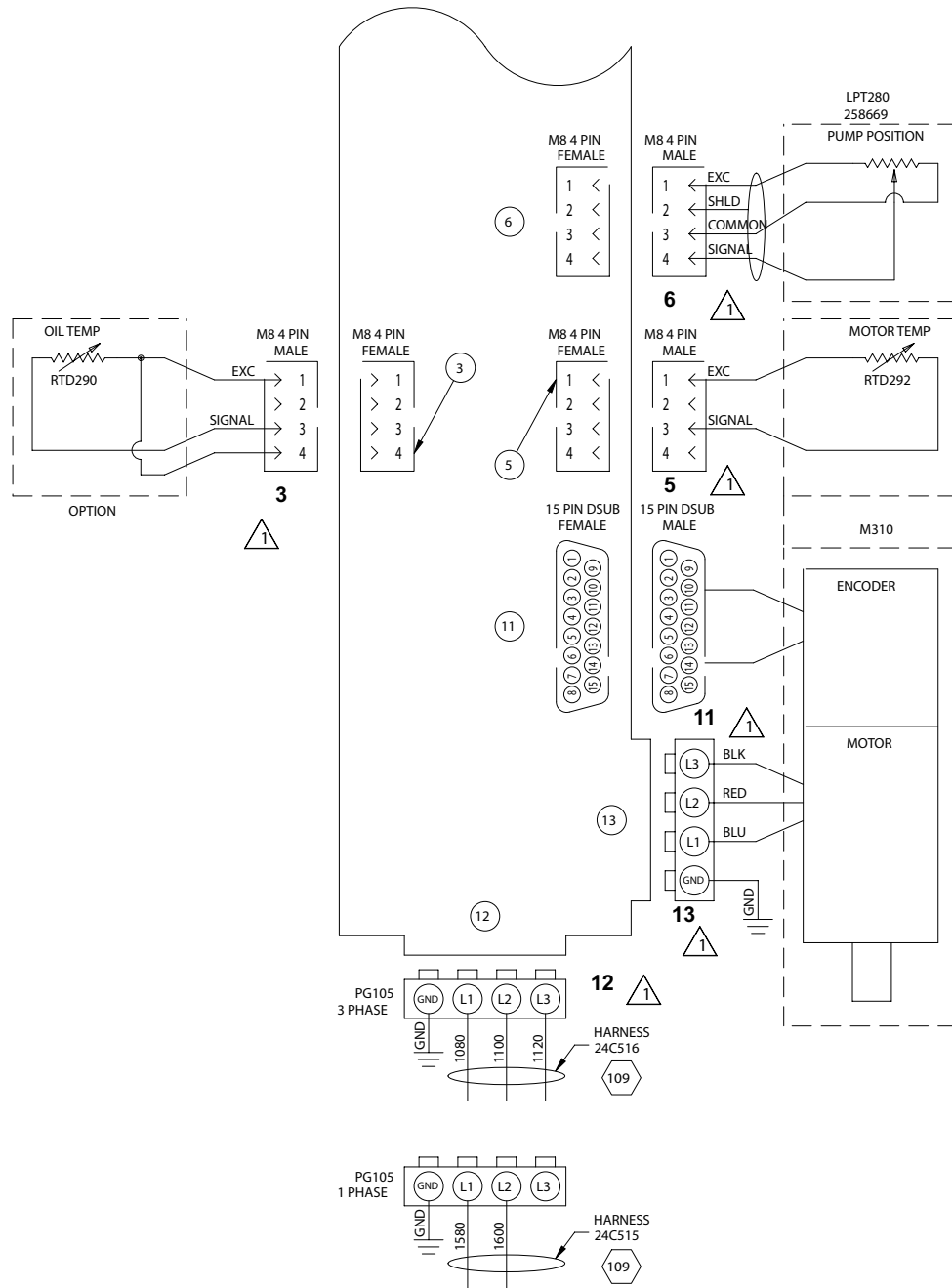

FIG. 39: Motor Control Module (MCM) Logic Drawing, Page 2 of 2

# Miscellaneous Power

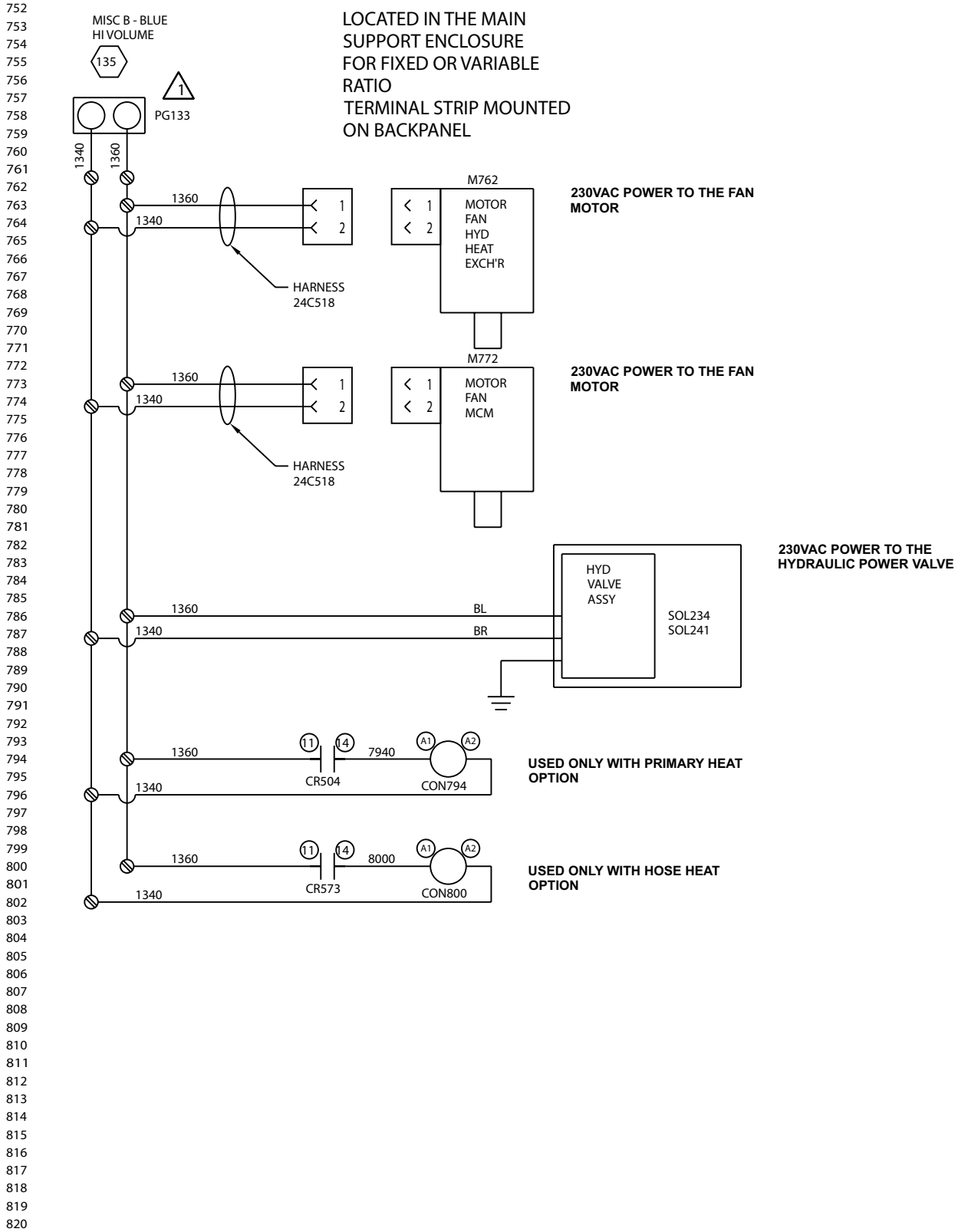

FIG. 40: Miscellaneous Power Logic Drawing, Page 1 of 2

821  
822  
823  
824  
825  
826  
827  
828  
829  
830  
831  
832  
833  
834  
835  
836  
837  
838  
839  
840  
841  
842  
843  
844  
845  
846  
847  
848  
849  
850  
851  
852  
853  
854  
855  
856  
857  
858  
859  
860  
861  
862  
863  
864  
865  
866  
867  
868  
869  
870  
871  
872  
873  
874  
875  
876  
877  
878  
879  
880  
881  
882  
883  
884  
885  
886  
887  
888  
889

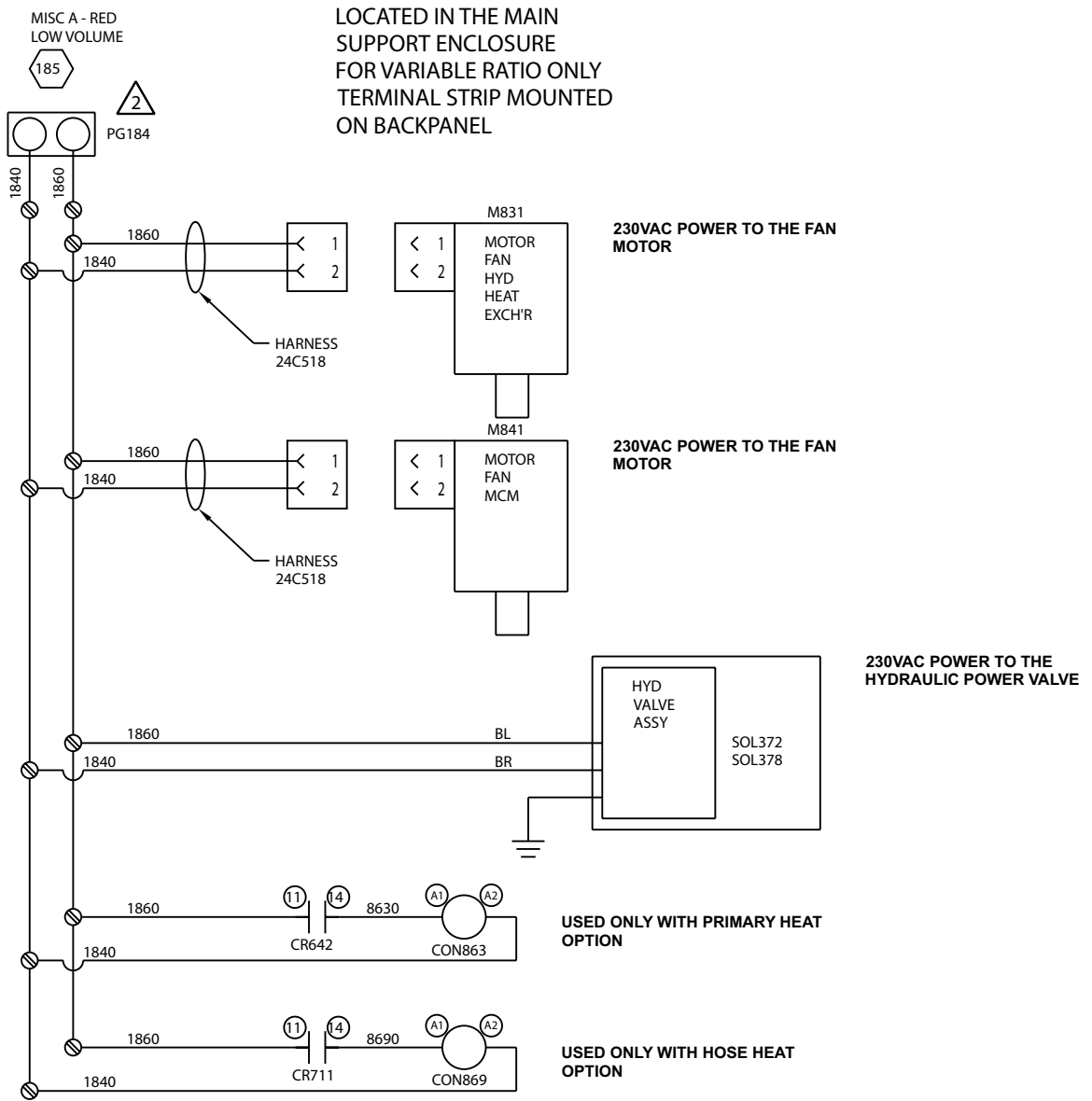

FIG. 41: Miscellaneous Power Logic Drawing, Page 2 of 2

## Technical Data

Maximum Fluid Working Pressure . . .	3000 psi (20.7 MPa, 207 bar)
Maximum Fluid Temperature . . . . .	190°F (88°C)
Fluid Inlet Feed Pressure Range . . . .	50 psi (0.35 MPa, 3.5 bar) to 250 psi (1.75 MPa, 17.5 bar)
Fluid Inlets . . . . .	<i>Component A (Red):</i> 1/2 npt(f) <i>Component B (Blue):</i> 3/4 npt(f)
Fluid Outlets. . . . .	<i>Component A (Red):</i> #8 (1/2 in.) JIC (3/4-16 unf), with #5 (5/16 in.) JIC adapter <i>Component B (Blue):</i> #10 (5/8 in.) JIC (7/8-14 unf), with #6 (3/8 in.) JIC adapter
Fluid Circulation Ports . . . . .	1/4 npsm(m), with plastic tubing, 250 psi (1.75 MPa, 17.5 bar) maximum
Line Voltage Requirement . . . . .	<i>230V / 1 phase and 230V / 3 phase Models:</i> 195-264V, 50/60 Hz <i>400V / 3 phase:</i> 360-440V, 50/60 Hz
Amperage Requirement. . . . .	See <b>Models</b> on page 4
Sound Power . . . . .	93 dB
Heater Power (A (Red) and B (Blue) heaters total, no hose, Heated HFR Models only). . .	12 kW
Hydraulic reservoir capacity. . . . .	8 gal. (30 liters)
Recommended hydraulic fluid . . . . .	Citgo A/W Hydraulic Oil, ISO Grade 46
Weight . . . . .	<i>Units with 12 kW Heaters:</i> 868 lb (394 kg) <i>Units without heaters:</i> 634 lb (288 kg)
Wetted Parts . . . . .	Aluminum, stainless steel, zinc-plated carbon steel, brass, carbide, chrome, fluoroelastomer, PTFE, ultra-high molecular weight polyethylene, chemically resistant o-rings

*All other brand names or marks are used for identification purposes and are trademarks of their respective owners.*



## Motor Control Module Technical Data

### Input Specifications

Input Line Voltage . . . . .	0-264 Vac, line-to-line
Input Line Phasing . . . . .	Single or Three Phase
Input Line Frequency . . . . .	50/60 Hz
Input Current per Phase. . . . .	25A (three-phase), 50A (single-phase)
Maximum Branch Circuit Protection Rating: . . . . .	30A (three-phase), 63A (single-phase)
Short Circuit Current Rating. . . . .	5 kA

### Output Specifications

Output Line Voltage . . . . .	0-264 Vac
Output Line Phasing . . . . .	Three Phase
Output Current . . . . .	0-30A
Output Overload. . . . .	200% for 0.2 seconds

DC Power Supply . . . . .	24 Vdc, Class 2, Graco-provided power supply
Enclosure . . . . .	Type 1
Max Ambient Temperature . . . . .	50°C (122°F)

*Overtemperature protection is provided to protect from motor overload.*

*Current limit, set via the software, is provided as a secondary protection from motor overload.*

*All installations and wiring must comply with NEC and local electrical codes.*

# Graco Standard Warranty

Graco warrants all equipment referenced in this document which is manufactured by Graco and bearing its name to be free from defects in material and workmanship on the date of sale to the original purchaser for use. With the exception of any special, extended, or limited warranty published by Graco, Graco will, for a period of twelve months from the date of sale, repair or replace any part of the equipment determined by Graco to be defective. This warranty applies only when the equipment is installed, operated and maintained in accordance with Graco's written recommendations.

This warranty does not cover, and Graco shall not be liable for general wear and tear, or any malfunction, damage or wear caused by faulty installation, misapplication, abrasion, corrosion, inadequate or improper maintenance, negligence, accident, tampering, or substitution of non-Graco component parts. Nor shall Graco be liable for malfunction, damage or wear caused by the incompatibility of Graco equipment with structures, accessories, equipment or materials not supplied by Graco, or the improper design, manufacture, installation, operation or maintenance of structures, accessories, equipment or materials not supplied by Graco.

This warranty is conditioned upon the prepaid return of the equipment claimed to be defective to an authorized Graco distributor for verification of the claimed defect. If the claimed defect is verified, Graco will repair or replace free of charge any defective parts. The equipment will be returned to the original purchaser transportation prepaid. If inspection of the equipment does not disclose any defect in material or workmanship, repairs will be made at a reasonable charge, which charges may include the costs of parts, labor, and transportation.

**THIS WARRANTY IS EXCLUSIVE, AND IS IN LIEU OF ANY OTHER WARRANTIES, EXPRESS OR IMPLIED, INCLUDING BUT NOT LIMITED TO WARRANTY OF MERCHANTABILITY OR WARRANTY OF FITNESS FOR A PARTICULAR PURPOSE.**

Graco's sole obligation and buyer's sole remedy for any breach of warranty shall be as set forth above. The buyer agrees that no other remedy (including, but not limited to, incidental or consequential damages for lost profits, lost sales, injury to person or property, or any other incidental or consequential loss) shall be available. Any action for breach of warranty must be brought within two (2) years of the date of sale.

**GRACO MAKES NO WARRANTY, AND DISCLAIMS ALL IMPLIED WARRANTIES OF MERCHANTABILITY AND FITNESS FOR A PARTICULAR PURPOSE, IN CONNECTION WITH ACCESSORIES, EQUIPMENT, MATERIALS OR COMPONENTS SOLD BUT NOT MANUFACTURED BY GRACO.** These items sold, but not manufactured by Graco (such as electric motors, switches, hose, etc.), are subject to the warranty, if any, of their manufacturer. Graco will provide purchaser with reasonable assistance in making any claim for breach of these warranties.

In no event will Graco be liable for indirect, incidental, special or consequential damages resulting from Graco supplying equipment hereunder, or the furnishing, performance, or use of any products or other goods sold hereto, whether due to a breach of contract, breach of warranty, the negligence of Graco, or otherwise.

## **FOR GRACO CANADA CUSTOMERS**

The Parties acknowledge that they have required that the present document, as well as all documents, notices and legal proceedings entered into, given or instituted pursuant hereto or relating directly or indirectly hereto, be drawn up in English. Les parties reconnaissent avoir convenu que la rédaction du présente document sera en Anglais, ainsi que tous documents, avis et procédures judiciaires exécutés, donnés ou intentés, à la suite de ou en rapport, directement ou indirectement, avec les procédures concernées.

# Graco Information

For the latest information about Graco products, visit [www.graco.com](http://www.graco.com).

**TO PLACE AN ORDER**, contact your Graco distributor or call to identify the nearest distributor.

**Phone:** 612-623-6921 **or Toll Free:** 1-800-328-0211 **Fax:** 612-378-3505

*All written and visual data contained in this document reflects the latest product information available at the time of publication.  
Graco reserves the right to make changes at any time without notice.*

*For patent information, see [www.graco.com/patents](http://www.graco.com/patents).*

*Original instructions. This manual contains English. MM 313998*

**Graco Headquarters:** Minneapolis  
**International Offices:** Belgium, China, Japan, Korea

**GRACO INC. AND SUBSIDIARIES • P.O. BOX 1441 • MINNEAPOLIS MN 55440-1441 • USA**

Copyright 2010, Graco Inc. All Graco manufacturing locations are registered to ISO 9001.

[www.graco.com](http://www.graco.com)

Revised October 2012